

# Quantum Mechanics as Quantum Information (and only a little more)

Christopher A. Fuchs  
*Computing Science Research Center  
Bell Labs, Lucent Technologies  
Room 2C-420, 600-700 Mountain Ave.  
Murray Hill, New Jersey 07974, USA*

## Abstract

In this paper, I try once again to cause some good-natured trouble. The issue remains, when will we ever stop burdening the taxpayer with conferences devoted to the quantum foundations? The suspicion is expressed that no end will be in sight until a means is found to reduce quantum theory to two or three statements of crisp physical (rather than abstract, axiomatic) significance. In this regard, no tool appears better calibrated for a direct assault than quantum information theory. Far from a strained application of the latest fad to a time-honored problem, this method holds promise precisely because a large part—*but not all*—of the structure of quantum theory has always concerned information. It is just that the physics community needs reminding.

This paper, though taking [quant-ph/0106166](#) as its core, corrects one mistake and offers several observations beyond the previous version. In particular, I identify one element of quantum mechanics that I would *not* label a subjective term in the theory—it is the integer parameter  $D$  traditionally ascribed to a quantum system via its Hilbert-space dimension.

## 1 Introduction<sup>1</sup>

Quantum theory as a weather-sturdy structure has been with us for 75 years now. Yet, there is a sense in which the struggle for its construction remains. I say this because one can check that not a year has gone by in the last 30 when there was not a meeting or conference devoted to some aspect of the quantum foundations. Our meeting in Växjö, “Quantum Theory: Reconsideration of Foundations,” is only one in a long, dysfunctional line.

But how did this come about? What is the cause of this year-after-year sacrifice to the “great mystery?” Whatever it is, it cannot be for want of a self-ordained solution: Go to any meeting, and it is like being in a holy city in great tumult. You will find all the religions with all their priests pitted in holy war—the Bohmians [3], the Consistent Historians [4], the Transactionalists [5], the Spontaneous Collapseans [6], the Einselectionists [7], the Contextual Objectivists [8], the outright Everettics [9, 10], and many more beyond that. They all declare to see the light, the ultimate light. Each tells us that if we will accept their solution as our savior, then we too will see the light.

---

<sup>1</sup>This paper, though substantially longer, should be viewed as a continuation and amendment to Ref. [1]. Details of the changes can be found in the Appendix to the present paper, Section 11. Substantial further arguments defending a transition from the “objective Bayesian” stance implicit in Ref. [1] to the “subjective Bayesian” stance implicit here can be found in Ref. [2].

## A Fraction of the Quantum Foundations Meetings since 1972

1972	The Development of the Physicist's Conception of Nature, Trieste, Italy
1973	Foundations of Quantum Mechanics and Ordered Linear Spaces, Marburg, Germany
1974	Quantum Mechanics, a Half Century Later, Strasbourg, France
1975	Foundational Problems in the Special Sciences, London, Canada
1976	International Symposium on Fifty Years of the Schrödinger Equation, Vienna, Austria
1977	International School of Physics "Enrico Fermi", Course LXXII: Problems in the Foundations of Physics, Varenna, Italy
1978	Stanford Seminar on the Foundations of Quantum Mechanics, Stanford, USA
1979	Interpretations and Foundations of Quantum Theory, Marburg, Germany
1980	Quantum Theory and the Structures of Time and Space, Tutzing, Germany
1981	NATO Advanced Study Institute on Quantum Optics, Experimental Gravitation, and Measurement Theory, Bad Windsheim, Germany
1982	The Wave-Particle Dualism: a Tribute to Louis de Broglie, Perugia, Italy
1983	Foundations of Quantum Mechanics in the Light of New Technology, Tokyo, Japan
1984	Fundamental Questions in Quantum Mechanics, Albany, New York
1985	Symposium on the Foundations of Modern Physics: 50 Years of the Einstein-Podolsky-Rosen Gedankenexperiment, Joensuu, Finland
1986	New Techniques and Ideas in Quantum Measurement Theory, New York, USA
1987	Symposium on the Foundations of Modern Physics 1987: The Copenhagen Interpretation 60 Years after the Como Lecture, Joensuu, Finland
1988	Bell's Theorem, Quantum Theory, and Conceptions of the Universe, Washington, DC, USA
1989	Sixty-two Years of Uncertainty: Historical, Philosophical and Physical Inquiries into the Foundations of Quantum Mechanics, Erice, Italy
1990	Symposium on the Foundations of Modern Physics 1990: Quantum Theory of Measurement and Related Philosophical Problems, Joensuu, Finland
1991	Bell's Theorem and the Foundations of Modern Physics, Cesena, Italy
1992	Symposia on the Foundations of Modern Physics 1992: The Copenhagen Interpretation and Wolfgang Pauli, Helsinki, Finland
1993	International Symposium on Fundamental Problems in Quantum Physics, Oviedo, Spain
1994	Fundamental Problems in Quantum Theory, Baltimore, USA
1995	The Dilemma of Einstein, Podolsky and Rosen, 60 Years Later, Haifa, Israel
1996	2nd International Symposium on Fundamental Problems in Quantum Physics, Oviedo, Spain
1997	Sixth UK Conference on Conceptual and Mathematical Foundations of Modern Physics, Hull, England
1998	Mysteries, Puzzles, and Paradoxes in Quantum Mechanics, Garda Lake, Italy
1999	2nd Workshop on Fundamental Problems in Quantum Theory, Baltimore, USA
2000	NATO Advanced Research Workshop on Decoherence and its Implications in Quantum Computation and Information Transfer, Mykonos, Greece
2001	Quantum Theory: Reconsideration of Foundations, Växjö, Sweden

But there has to be something wrong with this! If any of these priests had truly shown the light, there simply would not be the year-after-year conference. The verdict seems clear enough: If we—i.e., the set of people who might be reading this paper—really care about quantum foundations, then it behooves us as a community to ask why these meetings are happening and find a way to put a stop to them.

My view of the problem is this. Despite the accusations of incompleteness, nonsensicality,

irrelevance, and surreality one often sees one religion making against the other, I see little to no difference in *any* of their canons. They all look equally detached from the world of quantum practice to me. For, though each seems to want a firm reality within the theory—i.e., a single God they can point to and declare, “There, that term is what is real in the universe even when there are no physicists about”—none have worked very hard to get out of the Platonic realm of pure mathematics to find it.

What I mean by this deliberately provocative statement is that in spite of the differences in what the churches label<sup>2</sup> to be “real” in quantum theory,<sup>3</sup> they nonetheless all proceed from the same *abstract* starting point—the standard textbook accounts of the *axioms* of quantum theory.<sup>4</sup>

**The Canon for Most of the Quantum Churches:**  
The Axioms (plain and simple)

1. For every system, there is a complex Hilbert space  $\mathcal{H}$ .
  2. States of the system correspond to projection operators onto  $\mathcal{H}$ .
  3. Those things that are observable *somehow* correspond to the eigenprojectors of Hermitian operators.
  4. Isolated systems evolve according to the Schrödinger equation.
- ⋮

“But what nonsense is this,” you must be asking. “Where else could they start?” The main issue is this, and no one has said it more clearly than Carlo Rovelli [11]. Where present-day quantum-foundation studies have stagnated in the stream of history is not so unlike where the physics of length contraction and time dilation stood before Einstein’s 1905 paper on special relativity.

The Lorentz transformations have the name they do, rather than, say, the Einstein transformations, for good reason: Lorentz had published some of them as early as 1895. Indeed one could say that most of the empirical predictions of special relativity were in place well before Einstein came onto the scene. But that was of little consolation to the pre-Einsteinian physics community striving so hard to make sense of electromagnetic phenomena and the luminiferous ether. Precisely because the *only* justification for the Lorentz transformations appeared to be their *empirical adequacy*, they remained a mystery to be conquered. More particularly, this was a mystery that heaping further *ad hoc* (mathematical) structure onto could not possibly solve.

<sup>2</sup>Or *add* to the theory, as the case may be.

<sup>3</sup>Very briefly, a *cartoon* of some of the positions might be as follows. For the Bohmians, “reality” is captured by supplementing the state vector with an actual trajectory in coordinate space. For the Everettians, it is the universal wave function and the universe’s Hamiltonian. (Depending upon the persuasion, though, these two entities are sometimes supplemented with the terms in various Schmidt decompositions of the universal state vector with respect to various preconceived tensor-product structures.) For the Spontaneous Collapsians it is again the state vector—though now for the individual system—but Hamiltonian dynamics is supplemented with an objective collapse mechanism. For the Consistent Historians “reality” is captured with respect to an initial quantum state and a Hamiltonian by the addition of a set of preferred positive-operator valued measures (POVMs)—they call them consistent sets of histories—along with a truth-value assignment within each of those sets.

<sup>4</sup>To be fair, they do, each in their own way, contribute minor modifications to the *meanings* of a few *words* in the axioms. But that is essentially where the effort stops.

What was being begged for in the years between 1895 and 1905 was an understanding of the *origin* of that abstract, mathematical structure—some simple, crisp *physical* statements with respect to which the necessity of the mathematics would be indisputable. Einstein supplied that and became one of the greatest physicists of all time. He reduced the mysterious structure of the Lorentz transformations to two simple statements expressible in common language:

- 1) the speed of light in empty space is independent of the speed of its source,
- 2) physics should appear the same in all inertial reference frames.

The deep significance of this for the quantum problem should stand up and speak overpoweringly to anyone who admires these principles.

Einstein’s move effectively stopped all further debate on the origins of the Lorentz transformations. Outside of the time of the Nazi regime in Germany [12], I suspect there have been less than a handful of conferences devoted to “interpreting” them. Most importantly, with the supreme simplicity of Einstein’s principles, physics became ready for “the next step.” Is it possible to imagine that any mind—even Einstein’s—could have made the leap to general relativity directly from the original, abstract structure of the Lorentz transformations? A structure that was only empirically adequate? I would say no. Indeed, one can dream of the wonders we will find in pursuing the same strategy of simplification for the quantum foundations.

Symbolically, where we are:	Where we need to be:
$x' = \frac{x - vt}{\sqrt{1 - v^2/c^2}}$ $t' = \frac{t - vx/c^2}{\sqrt{1 - v^2/c^2}}$	<p style="text-align: center;">Speed of light is constant.</p> <p style="text-align: center;">Physics is the same in all inertial frames.</p>

The task is not to make sense of the quantum axioms by heaping more structure, more definitions, more science-fiction imagery on top of them, but to throw them away wholesale and start afresh. We should be relentless in asking ourselves: From what deep *physical* principles might we *derive* this exquisite mathematical structure? Those principles should be crisp; they should be compelling. They should stir the soul. When I was in junior high school, I sat down with Martin Gardner’s book *Relativity for the Million* [13] and came away with an understanding of the subject that sustains me today: The concepts were strange, but they were clear enough that I could get a grasp on them knowing little more mathematics than simple arithmetic. One should expect no less for a proper foundation to quantum theory. Until we can explain quantum theory’s *essence* to a junior-high-school or high-school student and have them walk away with a deep, lasting memory, we will have not understood a thing about the quantum foundations.

So, throw the existing axioms of quantum mechanics away and start afresh! But how to proceed? I myself see no alternative but to contemplate deep and hard the tasks, the techniques, and the implications of quantum information theory. The reason is simple, and I think inescapable. Quantum mechanics has always been about information. It is just that the physics community has somehow forgotten this.

**Quantum Mechanics:**  
*The Axioms and Our Imperative!*

<p>States correspond to density operators <math>\rho</math> over a Hilbert space <math>\mathcal{H}</math>.</p> <p>Measurements correspond to positive operator-valued measures (POVMs) <math>\{E_d\}</math> on <math>\mathcal{H}</math>.</p> <p><math>\mathcal{H}</math> is a complex vector space, not a real vector space, not a quaternionic module.</p> <p>Systems combine according to the tensor product of their separate vector spaces, <math>\mathcal{H}_{AB} = \mathcal{H}_A \otimes \mathcal{H}_B</math>.</p> <p>Between measurements, states evolve according to trace-preserving completely positive linear maps.</p> <p>By way of measurement, states evolve (up to normalization) via outcome-dependent completely positive linear maps.</p> <p>Probabilities for the outcomes of a measurement obey the Born rule for POVMs <math>\text{tr}(\rho E_d)</math>.</p>	<p style="text-align: center;"><i>Give an information theoretic reason if possible!</i></p> <p style="text-align: center;"><i>Give an information theoretic reason if possible!</i></p> <p style="text-align: center;"><i>Give an information theoretic reason if possible!</i></p> <p style="text-align: center;"><i>Give an information theoretic reason if possible!</i></p> <p style="text-align: center;"><i>Give an information theoretic reason if possible!</i></p> <p style="text-align: center;"><i>Give an information theoretic reason if possible!</i></p> <p style="text-align: center;"><i>Give an information theoretic reason if possible!</i></p>
<p>The distillate that remains—the piece of quantum theory with no information theoretic significance—will be our first unadorned glimpse of “quantum reality.” Far from being the end of the journey, placing this conception of nature in open view will be the start of a great adventure.</p>	

This, I see as the line of attack we should pursue with relentless consistency: The quantum system represents something real and independent of us; the quantum state represents a collection of subjective degrees of belief about *something* to do with that system (even if only in connection with our experimental kicks to it).<sup>5</sup> The structure called quantum mechanics is about the interplay of these two things—the subjective and the objective. The task before us is to separate the wheat

<sup>5</sup>“But physicists are, at bottom, a naive breed, forever trying to come to terms with the ‘world out there’ by methods which, however imaginative and refined, involve in essence the same element of contact as a well-placed kick.” — B. S. DeWitt and R. N. Graham [14]

from the chaff. If the quantum state represents subjective information, then how much of its mathematical support structure might be of that same character? Some of it, maybe most of it, but surely not all of it.

Our foremost task should be to go to each and every axiom of quantum theory and give it an information theoretic justification if we can. Only when we are finished picking off all the terms (or combinations of terms) that can be interpreted as subjective information will we be in a position to make real progress in quantum foundations. The raw distillate left behind—minuscule though it may be with respect to the full-blown theory—will be our first glimpse of what quantum mechanics is trying to tell us about nature itself.

Let me try to give a better way to think about this by making use of Einstein again. What might have been his greatest achievement in building general relativity? I would say it was in his recognizing that the “gravitational field” one feels in an accelerating elevator is a coordinate effect. That is, the “field” in that case is something induced purely with respect to the description of an observer. In this light, the program of trying to develop general relativity boiled down to recognizing all the things within gravitational and motional phenomena that should be viewed as consequences of our coordinate choices. It was in identifying all the things that are “numerically additional” [15] to the observer-free situation—i.e., those things that come about purely by bringing the observer (scientific agent, coordinate system, etc.) back into the picture.

This was a true breakthrough. For in weeding out all the things that can be interpreted as coordinate effects, the fruit left behind finally becomes clear to sight: It is the Riemannian manifold we call spacetime—a mathematical object, the study of which one can hope will tell us something about nature itself, not merely about the observer in nature.

The dream I see for quantum mechanics is just this. Weed out all the terms that have to do with gambling commitments, information, knowledge, and belief, and what is left behind will play the role of Einstein’s manifold. That is our goal. When we find it, it may be little more than a minuscule part of quantum *theory*. But being a clear window into nature, we may start to see sights through it we could hardly imagine before.<sup>6</sup>

## 2 Summary

I say to the House as I said to ministers who have joined this government, I have nothing to offer but blood, toil, tears, and sweat. We have before us an ordeal of the most grievous kind. We have before us many, many months of struggle and suffering. You ask, what is our policy? I say it is to wage war. War with all our might and with all the strength God has given us. You ask, what is our aim? I can answer in one word. It is victory.

— *Winston Churchill*, 1940, abridged

This paper is about taking the imperative in the Introduction seriously, though it contributes only a small amount to the labor it asks. Just as in the founding of quantum mechanics, this is

---

<sup>6</sup>I should point out to the reader that in opposition to the picture of general relativity, where reintroducing the coordinate system—i.e., reintroducing the observer—changes nothing about the manifold (it only tells us what kind of sensations the observer will pick up), I do not suspect the same for the quantum world. Here I suspect that reintroducing the observer will be more like introducing matter into pure spacetime, rather than simply gridding it off with a coordinate system. “Matter tells spacetime how to curve (when matter is there), and spacetime tells matter how to move (when matter is there).” [16] Observers, scientific agents, a necessary part of reality? No. But do they tend to change things once they are on the scene? Yes. If quantum mechanics can tell us something truly deep about nature, I think it is this.

not something that will spring forth from a lone mind in the shelter of a medieval college.<sup>7</sup> It is a task for a community with diverse but productive points of view. The quantum information community is nothing if not that.<sup>8</sup> “Philosophy is too important to be left to the philosophers,” John Archibald Wheeler once said. Likewise, I am apt to say for the quantum foundations.

The structure of the remainder of the paper is as follows. In Section 3 “**Why Information?**,” I reiterate the cleanest argument I know of that the quantum state is solely an expression of subjective information—the information one has about a quantum system. It has no objective reality in and of itself.<sup>9</sup> The argument is then refined by considering the phenomenon of quantum teleportation [23].

In Section 4 “**Information About What?**,” I tackle that very question [24] head-on. The answer is “the potential consequences of our experimental interventions into nature.” Once freed from the notion that quantum measurement ought to be about revealing traces of some preexisting property [25] (or beable [26]), one finds no particular reason to take the standard account of measurement (in terms of complete sets of orthogonal projection operators) as a basic notion. Indeed quantum information theory, with its emphasis on the utility of generalized measurements or positive operator-valued measures (POVMs) [27], suggests one should take those entities as the basic notion instead. The productivity of this point of view is demonstrated by the enticingly simple Gleason-like derivation of the quantum probability rule recently found by Paul Busch [28] and, independently, by Joseph Renes and collaborators [29]. Contrary to Gleason’s original theorem [30], this theorem works just as well for two-dimensional Hilbert spaces, and even for Hilbert spaces over the field of rational numbers. In Section 4.1, I give a strengthened argument for the noncontextuality assumption in this theorem. In Section 4.2, “Le Bureau International des Poids et Mesures à Paris,” I start the process of defining what it means—from the Bayesian point of view—to accept quantum mechanics as a theory. This leads to the notion of fixing a fiducial or standard quantum measurement for defining the very meaning of a quantum state.

In Section 5 “**Wither Entanglement?**,” I ask whether entanglement is all it is touted to be as far as quantum foundations are concerned. That is, is entanglement really as Schrödinger said, “*the characteristic trait of quantum mechanics, the one that enforces its entire departure from classical lines of thought?*” To combat this, I give a simple derivation of the tensor-product rule for combining Hilbert spaces of individual systems which takes the structure of *localized* quantum measurements as its starting point. In particular, the derivation makes use of Gleason-like considerations in the

---

<sup>7</sup>If you want to know what this means, ask me over a beer sometime.

<sup>8</sup>There have been other soundings of the idea that information and computation theory can tell us something deep about the foundations of quantum mechanics. See Refs. [17], [18], [19], and in particular Ref. [20].

<sup>9</sup>In the previous version of this paper, [quant-ph/0106166](#), I variously called quantum states “information” and “states of knowledge” and did not emphasize so much the “radical” Bayesian idea that the probability one *ascribes* to a phenomenon amounts to *nothing* more than the gambling commitments one is willing to make with regard to that phenomenon. To the “radical” Bayesian, probabilities are subjective all the way to the bone. In this paper, I start the long process of trying to turn my earlier de-emphasis around (even though it is somewhat dangerous to attempt this in a manuscript that is little more than a modification of an already completed paper). In particular, because of the objective overtones of the word “knowledge”—i.e., that a particular piece of knowledge is either “right” or “wrong”—I try to steer clear from the term as much as possible in the present version. The conception working in the background of this paper is that there is simply no such thing as a “right and true” quantum state. In all cases, a quantum state is specifically and only a mathematical symbol for capturing a set of beliefs or gambling commitments. Thus I now variously call quantum states “beliefs,” “states of belief,” “information” (though, by this I mean “information” in a more subjective sense than is becoming common in the quantum information community), “judgments,” “opinions,” and “gambling commitments.” Believe me, I already understand well the number of jaws that will drop from the adoption of this terminology. However, if the reader finds that this gives him a sense of butterflies in the stomach—or fears that I will become a solipsist [21] or a crystal-toting New Age practitioner of homeopathic medicine [22]—I hope he will keep in mind that this attempt to be absolutely frank about the subjectivity of **some** of the terms in quantum theory is part of a larger program to delimit the terms that *can be* interpreted as objective in a fruitful way.

presence of classical communication. With the tensor-product structure established, the very notion of entanglement follows in step. This shows how entanglement, just like the standard probability rule, is secondary to the structure of quantum measurements. Moreover, “locality” is built in at the outset; there is simply nothing mysterious and nonlocal about entanglement.

In Section 6 “**Whither Bayes Rule?**,” I ask why one should expect the rule for updating quantum state assignments upon the completion of a measurement to take the form it actually does. Along the way, I give a simple derivation that one’s information always increases on average for *any* quantum mechanical measurement that does not itself discard information. (Despite the appearance otherwise, this is not a tautology!) Most importantly, the proof technique used for showing the theorem indicates an extremely strong analogy between quantum collapse and Bayes’ rule in classical probability theory: Up to an overall unitary “readjustment” of one’s final probabilistic beliefs—the readjustment takes into account one’s initial state for the system as well as one’s description of the measurement interaction—quantum collapse is *precisely* Bayesian conditionalization. This in turn gives more impetus for the assumptions behind the Gleason-like theorems of the previous two sections. In Section 6.1, “Accepting Quantum Mechanics,” I complete the process started in Section 4.2 and describe quantum measurement in Bayesian terms: An everyday measurement is any *I-know-not-what* that leads to an application of Bayes rule with respect to one’s belief about the potential outcome of the standard quantum measurement.

In Section 7, “**What Else is Information?**,” I argue that, to the extent that a quantum state is a subjective quantity, so must be the assignment of a state-change rule  $\rho \rightarrow \rho_d$  for describing what happens to an initial quantum state upon the completion of a measurement—generally some POVM—whose outcome is  $d$ . In fact, the levels of subjectivity for the state and the state-change rule must be precisely the same for consistency’s sake. To draw an analogy to Bayesian probability theory, the initial state  $\rho$  plays the role of an a priori probability distribution  $P(h)$  for some hypothesis, the final state  $\rho_d$  plays the role of a posterior probability distribution  $P(h|d)$ , and the state-change rule  $\rho \rightarrow \rho_d$  plays the role of the “statistical model”  $P(d|h)$  enacting the transition  $P(h) \rightarrow P(h|d)$ . To the extent that *all* Bayesian probabilities are subjective—even the probabilities  $P(d|h)$  of a statistical model—so is the mapping  $\rho \rightarrow \rho_d$ . Specializing to the case that no information is gathered, one finds that the trace-preserving completely positive maps that describe quantum time-evolution are themselves nothing more than subjective judgments.

In Section 8 “**Intermission,**” I give a slight breather to sum up what has been trashed and where we are headed.

In Section 9 “**Unknown Quantum States?**,” I tackle the conundrum posed by these very words. Despite the phrase’s ubiquitous use in the quantum information literature, what can an *unknown* state be? A quantum state—from the present point of view, explicitly someone’s information—must always be known by someone, if it exists at all. On the other hand, for many an application in quantum information, it would be quite contrived to imagine that there is always someone in the background describing the system being measured or manipulated, and that what we are doing is grounding the phenomenon with respect to *his* state of belief. The solution, at least in the case of quantum-state tomography [31], is found through a quantum mechanical version of de Finetti’s classic theorem on “unknown probabilities.” This reports work from Refs. [32] and [33]. Maybe one of the most interesting things about the theorem is that it fails for Hilbert spaces over the field of real numbers, suggesting that perhaps the whole discipline of quantum information might not be well defined in that imaginary world.

Finally, in Section 10 “**The Oyster and the Quantum,**” I flirt with the most tantalizing question of all: Why the quantum? There is no answer here, but I do not discount that we are on the brink of finding one. In this regard no platform seems firmer for the leap than the very existence of quantum cryptography and quantum computing. The world is sensitive to our touch.



It has a kind of “Zing!”<sup>10</sup> that makes it fly off in ways that were not imaginable classically. The whole structure of quantum mechanics—*it is speculated*—may be nothing more than the optimal method of reasoning and processing information in the light of such a fundamental (wonderful) sensitivity. As a concrete proposal for a potential mathematical expression of “Zing!,” I consider the integer parameter  $D$  traditionally ascribed to a quantum system by way of its Hilbert-space dimension.

### 3 Why Information?

Realists can be tough customers indeed—but there is no reason to be afraid of them.

— Paul Feyerabend, 1992

Einstein was the master of clear thought; I have expressed my opinion of this with respect to both special and general relativity. But I can go further. I would say he possessed the same great penetrating power when it came to analyzing the quantum. For even there, he was immaculately clear and concise in his expression. In particular, he was the first person to say in absolutely unambiguous terms why the quantum state should be viewed as information (or, to say the same thing, as a representation of one’s beliefs and gambling commitments, credible or otherwise).

His argument was simply that a quantum-state assignment for a system can be forced to go one way or the other by interacting with a part of the world that should have no causal connection with the system of interest. The paradigm here is of course the one well known through the Einstein, Podolsky, Rosen paper [34], but simpler versions of the train of thought had a long pre-history with Einstein [35] himself.

The best was in essence this. Take two spatially separated systems  $A$  and  $B$  prepared in some entangled quantum state  $|\psi^{AB}\rangle$ . By performing the measurement of one or another of two observables on system  $A$  alone, one can *immediately* write down a new state for system  $B$ . Either the state will be drawn from one set of states  $\{|\phi_i^B\rangle\}$  or another  $\{|\eta_i^B\rangle\}$ , depending upon which observable is measured.<sup>11</sup> The key point is that it does not matter how distant the two systems are from each other, what sort of medium they might be immersed in, or any of the other fine details of the world. Einstein concluded that whatever these things called quantum states *be*, they cannot be “real states of affairs” for system  $B$  alone. For, whatever the real, objective state of affairs at  $B$  is, it should not depend upon the measurements one can make on a causally unconnected system  $A$ .

Thus one must take it seriously that the new state (either a  $|\phi_i^B\rangle$  or a  $|\eta_i^B\rangle$ ) represents information about system  $B$ . In making a measurement on  $A$ , one learns something about  $B$ , but that is where the story ends. The state change cannot be construed to be something more physical than that. More particularly, the final state itself for  $B$  cannot be viewed as more than a reflection of some tricky combination of one’s initial information and the knowledge gained through the measurement. Expressed in the language of Einstein, the quantum state cannot be a “complete” description of the quantum system.

Here is the way Einstein put it to Michele Besso in a 1952 letter [37]:

<sup>10</sup>Dash, verve, vigor, vim, zip, pep, punch, pizzazz!

<sup>11</sup>Generally there need be hardly any relation between the two sets of states: only that when the states are weighted by their probabilities, they mix together to form the initial density operator for system  $B$  alone. For a precise statement of this freedom, see Ref. [36].

What relation is there between the “state” (“quantum state”) described by a function  $\psi$  and a real deterministic situation (that we call the “real state”)? Does the quantum state characterize completely (1) or only incompletely (2) a real state?

One cannot respond unambiguously to this question, because each measurement represents a real uncontrollable intervention in the system (Heisenberg). The real state is not therefore something that is immediately accessible to experience, and its appreciation always rests hypothetical. (Comparable to the notion of force in classical mechanics, if one doesn’t fix *a priori* the law of motion.) Therefore suppositions (1) and (2) are, in principle, both possible. A decision in favor of one of them can be taken only after an examination and confrontation of the admissibility of their consequences.

I reject (1) because it obliges us to admit that there is a rigid connection between parts of the system separated from each other in space in an arbitrary way (instantaneous action at a distance, which doesn’t diminish when the distance increases). Here is the demonstration:

A system  $S_{12}$ , with a function  $\psi_{12}$ , which is known, is composed of two systems  $S_1$ , and  $S_2$ , which are very far from each other at the instant  $t$ . If one makes a “complete” measurement on  $S_1$ , which can be done in different ways (according to whether one measures, for example, the momenta or the coordinates), depending on the result of the measurement and the function  $\psi_{12}$ , one can determine by current quantum-theoretical methods, the function  $\psi_2$  of the second system. *This function can assume different forms*, according to the *procedure* of measurement applied to  $S_1$ .

But this is in contradiction with (1) *if one excludes action at a distance*. Therefore the measurement on  $S_1$  has no effect on the real state  $S_2$ , and therefore assuming (1) no effect on the quantum state of  $S_2$  described by  $\psi_2$ .

I am thus forced to pass to the supposition (2) according to which the real state of a system is only described incompletely by the function  $\psi_{12}$ .

If one considers the method of the present quantum theory as being in principle definitive, that amounts to renouncing a complete description of real states. One could justify this renunciation if one assumes that there is no law for real states—i.e., that their description would be useless. Otherwise said, that would mean: laws don’t apply to things, but only to what observation teaches us about them. (The laws that relate to the temporal succession of this partial knowledge are however entirely deterministic.)

Now, I can’t accept that. I think that the statistical character of the present theory is simply conditioned by the choice of an incomplete description.

There are two issues in this letter that are worth disentangling. 1) Rejecting the rigid connection of all nature<sup>12</sup>—that is to say, admitting that the very notion of *separate systems* has any meaning at all—one is led to the conclusion that a quantum state cannot be a complete specification of a system. It must be information, at least in part. This point should be placed in contrast to the other well-known facet of Einstein’s thought: namely, 2) an unwillingness to accept such an “incompleteness” as a necessary trait of the physical world.

It is quite important to recognize that the first issue does not entail the second. Einstein had that firmly in mind, but he wanted more. His reason for going the further step was, I think, well justified *at the time* [38]:

There exists ... a simple psychological reason for the fact that this most nearly obvious interpretation is being shunned. For if the statistical quantum theory does not pretend to describe the individual system (and its development in time) completely, it appears unavoidable

---

<sup>12</sup>The rigid connection of all nature, on the other hand, is exactly what the Bohmians and Everetts *do* embrace, even glorify. So, I suspect these words will fall on deaf ears with them. But similarly would they fall on deaf ears with the believer who says that God wills each and every event in the universe and no further explanation is needed. No point of view should be dismissed out of hand: the overriding issue is simply which view will lead to the most progress, which view has the potential to close the debate, which view will give the most new phenomena for the physicist to have fun with?

to look elsewhere for a complete description of the individual system; in doing so it would be clear from the very beginning that the elements of such a description are not contained within the conceptual scheme of the statistical quantum theory. With this one would admit that, in principle, this scheme could not serve as the basis of theoretical physics.

But the world has seen much in the mean time. The last seventeen years have given confirmation after confirmation that the Bell inequality (and several variations of it) are indeed violated by the physical world. The Kochen-Specker no-go theorems have been meticulously clarified to the point where simple textbook pictures can be drawn of them [39]. Incompleteness, it seems, is here to stay: The theory prescribes that no matter how much we know about a quantum system—even when we have *maximal* information about it<sup>13</sup>—there will always be a statistical residue. There will always be questions that we can ask of a system for which we cannot predict the outcomes. In quantum theory, maximal information is simply not complete information [40]. But neither can it be completed. As Wolfgang Pauli once wrote to Markus Fierz [41], “The well-known ‘incompleteness’ of quantum mechanics (Einstein) is certainly an existent fact somehow-somewhere, but certainly cannot be removed by reverting to classical field physics.” Nor, I would add, will the mystery of that “existent fact” be removed by attempting to give the quantum state anything resembling an ontological status.

The complete disconnectedness of the quantum-state change rule from anything to do with spacetime considerations is telling us something deep: The quantum state is information. Subjective, incomplete information. Put in the right mindset, this is *not* so intolerable. It is a statement about our world. There is something about the world that keeps us from ever getting more information than can be captured through the formal structure of quantum mechanics. Einstein had wanted us to look further—to find out how the incomplete information could be completed—but perhaps the real question is, “Why can it *not* be completed?”

Indeed I think this is one of the deepest questions we can ask and still hope to answer. But first things first. The more immediate question for anyone who has come this far—and one that deserves to be answered forthright—is what is this information symbolized by a  $|\psi\rangle$  actually about? I have hinted that I would not dare say that it is about some kind of hidden variable (as the Bohmian might) or even about our place within the universal wavefunction (as the Everettic might).

Perhaps the best way to build up to an answer is to be true to the theme of this paper: quantum foundations in the light of quantum information. Let us forage the phenomena of quantum information to see if we might first refine Einstein’s argument. One need look no further than to the phenomenon of quantum teleportation [23]. Not only can a quantum-state assignment for a system be forced to go one way or the other by interacting with another part of the world of no causal significance, but, for the cost of two bits, one can make that quantum state assignment anything one wants it to be.

Such an experiment starts out with Alice and Bob sharing a maximally entangled pair of qubits in the state

$$|\psi^{AB}\rangle = \sqrt{\frac{1}{2}}(|0\rangle|0\rangle + |1\rangle|1\rangle). \quad (1)$$

Bob then goes to any place in the universe he wishes. Alice in her laboratory prepares another qubit with any state  $|\psi\rangle$  that she ultimately wants to impart onto Bob’s system. She performs a Bell-basis measurement on the two qubits in her possession. In the same vein as Einstein’s thought

---

<sup>13</sup>As should be clear from all my warnings, I am no longer entirely pleased with this terminology. I would now, for instance, refer to a pure quantum state as a “maximally rigid gambling commitment” or some such thing. See Ref. [2], pages 49–50 and 53–54. However, after trying to reconstruct this paragraph several times to be in conformity with my new terminology, I finally decided that a more accurate representation would break the flow of the section even more than this footnote!

experiment, Bob’s system immediately takes on the character of one of the states  $|\psi\rangle$ ,  $\sigma_x|\psi\rangle$ ,  $\sigma_y|\psi\rangle$ , or  $\sigma_z|\psi\rangle$ . But that is only insofar as Alice is concerned.<sup>14</sup> Since there is no (reasonable) causal connection between Alice and Bob, it must be that these states represent the possibilities for Alice’s updated beliefs about Bob’s system.

If now Alice broadcasts the result of her measurement to the world, Bob may complete the teleportation protocol by performing one of the four Pauli rotations ( $I$ ,  $\sigma_x$ ,  $\sigma_y$ ,  $\sigma_z$ ) on his system, conditioning it on the information he receives. The result, as far as Alice is concerned, is that Bob’s system finally resides predictably in the state  $|\psi\rangle$ .<sup>1516</sup>

How can Alice convince herself that such is the case? Well, if Bob is willing to reveal his location, she just need walk to his site and perform the **YES-NO** measurement:  $|\psi\rangle\langle\psi|$  vs.  $I - |\psi\rangle\langle\psi|$ . The outcome will be a **YES** with probability one for her if all has gone well in carrying out the protocol. Thus, for the cost of a measurement on a causally disconnected system and two bits worth of causal action on the system of actual interest—i.e., one of the four Pauli rotations—Alice can sharpen her predictability to complete certainty for *any* **YES-NO** observable she wishes.

Roger Penrose argues in his book *The Emperor’s New Mind* [42] that when a system “has” a state  $|\psi\rangle$  there ought to be some property in the system (in and of itself) that corresponds to its “ $|\psi\rangle$ ’ness.” For how else could the system be prepared to reveal a **YES** in the case that Alice actually checks it? Asking this rhetorical question with a sufficient amount of command is enough to make many a would-be informationist weak in knees. But there is a crucial oversight implicit in its confidence, and we have already caught it in action. If Alice fails to reveal her information to anyone else in the world, there is no one else who can predict the qubit’s ultimate revelation with certainty. More importantly, there is nothing in quantum mechanics that gives the qubit the power to stand up and say **YES** all by itself: If Alice does not take the time to walk over to it and interact with it, there is no revelation. There is only the confidence in Alice’s mind that, *should* she interact with it, she *could* predict the consequence<sup>17</sup> of that interaction.

## 4 Information About What?

I think that the sickliest notion of physics, even if a student gets it, is that it is ‘the science of masses, molecules, and the ether.’ And I think that the healthiest notion, even if a student does not wholly get it, is that physics is the science of the ways of taking hold of bodies and pushing them!

— *W. S. Franklin, 1903*

There are great rewards in being a new parent. Not least of all is the opportunity to have a close-up look at a mind in formation. Last year, I watched my two-year old daughter learn things at a fantastic rate, and though there were untold lessons for her, there were also a sprinkling for me. For instance, I started to see her come to grips with the idea that there is a world independent

---

<sup>14</sup>As far as Bob is concerned, nothing whatsoever changes about the system in his possession: It started in the completely mixed state  $\rho = \frac{1}{2}I$  and remains that way.

<sup>15</sup>As far as Bob is concerned, nothing whatsoever changes about the system in his possession: It started in the completely mixed state  $\rho = \frac{1}{2}I$  and remains that way.

<sup>16</sup>The repetition in these footnotes is not a typographical error.

<sup>17</sup>I adopt this terminology to be similar to L. J. Savage’s book, Ref. [43], Chapter 2, where he discusses the terms “the person,” “the world,” “consequences,” “acts,” and “decisions,” in the context of rational decision theory. “A **consequence** is anything that may happen to the person,” Savage writes, where we add “when he **acts** via the capacity of a quantum measurement.” In this paper, I call what Savage calls “the person” the agent, scientific agent, or observer instead.

of her desires. What struck me was the contrast between that and the gain of confidence I also saw grow in her that there are aspects of existence she *could* control. The two go hand in hand. She pushes on the world, and sometimes it gives in a way that she has learned to predict, and sometimes it pushes back in a way she has not foreseen (and may never be able to). If she could manipulate the world to the complete desires of her will—I became convinced—there would be little difference between wake and dream.

The main point is that she learns from her forays into the world. In my cynical moments, I find myself thinking, “How can she think that she’s learned anything at all? She has no theory of measurement. She leaves measurement completely undefined. How can she have a stake to knowledge if she does not have a theory of how she learns?”

Hideo Mabuchi once told me, “The quantum measurement problem refers to a set of people.” And though that is a bit harsh, maybe it also contains a bit of the truth. With the physics community making use of theories that tend to last between 100 and 300 years, we are apt to forget that scientific views of the world are built from the top down, not from the bottom up. The experiment is the basis of all which we try to describe with science. But an experiment is an active intervention into the course of nature on the part of the experimenter; it is not contemplation of nature from afar [44]. We set up this or that experiment to see how nature reacts. It is the conjunction of myriads of such interventions and their consequences that we record into our data books.<sup>18</sup>

We tell ourselves that we have learned something new when we can distill from the data a compact description of all that was seen and—even more tellingly—when we can dream up further experiments to corroborate that description. This is the minimal requirement of science. If, however, from such a description we can *further* distill a model of a free-standing “reality” independent of our interventions, then so much the better. I have no bone to pick with reality. It is the most solid thing we can hope for from a theory. Classical physics is the ultimate example in that regard. It gives us a compact description, but it can give much more if we want it to.

The important thing to realize, however, is that there is no logical necessity that such a world-view always be obtainable. If the world is such that we can never identify a reality—a *free-standing* reality—independent of our experimental interventions, then we must be prepared for that too. That is where quantum theory in its most minimal and conceptually simplest dispensation seems to stand [46]. It is a theory whose terms refer predominately to our interface with the world. It is a theory that cannot go the extra step that classical physics did without “writing songs I can’t

---

<sup>18</sup>But I must stress that I am not so positivistic as to think that physics should somehow be grounded on a primitive notion of “sense impression” as the philosophers of the Vienna Circle did. The interventions and their consequences that an experimenter records, have no option but to be thoroughly theory-laden. It is just that, in a sense, they are by necessity at least one theory behind. No one got closer to the salient point than Heisenberg (in a quote he attributed to Einstein many years after the fact) [45]:

It is quite wrong to try founding a theory on observable magnitudes alone. In reality the very opposite happens. It is the theory which decides what we can observe. You must appreciate that observation is a very complicated process. The phenomenon under observation produces certain events in our measuring apparatus. As a result, further processes take place in the apparatus, which eventually and by complicated paths produce sense impressions and help us to fix the effects in our consciousness. Along this whole path—from the phenomenon to its fixation in our consciousness—we must be able to tell how nature functions, must know the natural laws at least in practical terms, before we can claim to have observed anything at all. Only theory, that is, knowledge of natural laws, enables us to deduce the underlying phenomena from our sense impressions. When we claim that we can observe something new, we ought really to be saying that, although we are about to formulate new natural laws that do not agree with the old ones, we nevertheless assume that the existing laws—covering the whole path from the phenomenon to our consciousness—function in such a way that we can rely upon them and hence speak of “observation.”

believe, with words that tear and strain to rhyme” [47]. It is a theory not about observables, not about beables, but about “dingables.”<sup>19</sup> We tap a bell with our gentle touch and listen for its beautiful ring.

So what are the ways we can intervene on the world? What are the ways we can push it and wait for its unpredictable reaction? The usual textbook story is that those things that are measurable correspond to Hermitian operators. Or perhaps to say it in more modern language, to each observable there corresponds a set of orthogonal projection operators  $\{\Pi_i\}$  over a complex Hilbert space  $\mathcal{H}_D$  that form a complete resolution of the identity,

$$\sum_i \Pi_i = I. \quad (2)$$

The index  $i$  labels the potential outcomes of the measurement (or *intervention*, to slip back into the language promoted above). When an observer possesses the information  $\rho$ —captured most generally by a mixed-state density operator—quantum mechanics dictates that he can expect the various outcomes with a probability

$$P(i) = \text{tr}(\rho\Pi_i). \quad (3)$$

The best justification for this probability rule comes by way of Andrew Gleason’s amazing 1957 theorem [30]. For, it states that the standard rule is the *only* rule that satisfies a very simple kind of noncontextuality for measurement outcomes [48]. In particular, if one contemplates measuring two distinct observables  $\{\Pi_i\}$  and  $\{\Gamma_i\}$  which happen to share a single projector  $\Pi_k$ , then the probability of outcome  $k$  is independent of which observable it is associated with. More formally, the statement is this. Let  $\mathcal{P}_D$  be the set of projectors associated with a (real or complex) Hilbert space  $\mathcal{H}_D$  for  $D \geq 3$ , and let  $f : \mathcal{P}_D \rightarrow [0, 1]$  be such that

$$\sum_i f(\Pi_i) = 1 \quad (4)$$

whenever a set of projectors  $\{\Pi_i\}$  forms an observable. The theorem concludes that there exists a density operator  $\rho$  such that

$$f(\Pi) = \text{tr}(\rho\Pi). \quad (5)$$

In fact, in a single blow, Gleason’s theorem derives not only the probability rule, but also the state-space structure for quantum mechanical states (i.e., that it corresponds to the convex set of density operators).

In itself this is no small feat, but the thing that makes the theorem an “amazing” theorem is the sheer difficulty required to prove it [49]. Note that no restrictions have been placed upon the function  $f$  beyond the ones mentioned above. There is no assumption that it need be differentiable, nor that it even need be continuous. All of that, and linearity too, comes from the structure of the observables—i.e., that they are complete sets of orthogonal projectors onto a linear vector space.

Nonetheless, one should ask: Does this theorem really give *the physicist* a clearer vision of where the probability rule comes from? Astounding feats of mathematics are one thing; insight into physics is another. The two are often at opposite ends of the spectrum. As fortunes turn, a unifying strand can be drawn by viewing quantum foundations in the light of quantum information.

The place to start is to drop the fixation that the basic set of observables in quantum mechanics are complete sets of orthogonal projectors. In quantum information theory it has been found to be extremely convenient to expand the notion of measurement to also include general positive operator-valued measures (POVMs) [39, 50]. In other words, in place of the usual textbook notion

---

<sup>19</sup>Pronounced ding-ables.

of measurement, *any* set  $\{E_d\}$  of positive-semidefinite operators on  $\mathcal{H}_D$  that forms a resolution of the identity, i.e., that satisfies

$$\langle \psi | E_d | \psi \rangle \geq 0, \quad \text{for all } |\psi\rangle \in \mathcal{H}_D \quad (6)$$

and

$$\sum_d E_d = I, \quad (7)$$

counts as a measurement. The outcomes of the measurement are identified with the indices  $d$ , and the probabilities of the outcomes are computed according to a generalized Born rule,

$$P(d) = \text{tr}(\rho E_d). \quad (8)$$

The set  $\{E_d\}$  is called a POVM, and the operators  $E_d$  are called POVM elements. (In the non-standard language promoted earlier, the set  $\{E_d\}$  signifies an intervention into nature, while the individual  $E_d$  represent the potential consequences of that intervention.) Unlike standard measurements, there is no limitation on the number of values the index  $d$  can take. Moreover, the  $E_d$  may be of any rank, and there is no requirement that they be mutually orthogonal.

The way this expansion of the notion of measurement is *usually* justified is that any POVM can be represented formally as a standard measurement on an ancillary system that has interacted in the past with the system of actual interest. Indeed, suppose the system and ancilla are initially described by the density operators  $\rho_S$  and  $\rho_A$  respectively. The conjunction of the two systems is then described by the initial quantum state

$$\rho_{SA} = \rho_S \otimes \rho_A. \quad (9)$$

An interaction between the systems via some unitary time evolution leads to a new state

$$\rho_{SA} \longrightarrow U \rho_{SA} U^\dagger. \quad (10)$$

Now, imagine a standard measurement on the ancilla. It is described on the total Hilbert space via a set of orthogonal projection operators  $\{I \otimes \Pi_d\}$ . An outcome  $d$  will be found, by the standard Born rule, with probability

$$P(d) = \text{tr}\left(U(\rho_S \otimes \rho_A)U^\dagger(I \otimes \Pi_d)\right). \quad (11)$$

The number of outcomes in this seemingly indirect notion of measurement is limited only by the dimensionality of the ancilla's Hilbert space—in principle, there can be arbitrarily many.

As advertised, it turns out that the probability formula above can be expressed in terms of operators on the system's Hilbert space alone: This is the origin of the POVM. If we let  $|s_\alpha\rangle$  and  $|a_c\rangle$  be an orthonormal basis for the system and ancilla respectively, then  $|s_\alpha\rangle|a_c\rangle$  will be a basis for the composite system. Using the cyclic property of the trace in Eq. (11), we get

$$\begin{aligned} P(d) &= \sum_{\alpha c} \langle s_\alpha | \langle a_c | \left( (\rho_S \otimes \rho_A) U^\dagger (I \otimes \Pi_d) U \right) | s_\alpha \rangle | a_c \rangle \\ &= \sum_{\alpha} \langle s_\alpha | \rho_S \left( \sum_c \langle a_c | \left( (I \otimes \rho_A) U^\dagger (I \otimes \Pi_d) U \right) | a_c \rangle \right) | s_\alpha \rangle. \end{aligned} \quad (12)$$

Letting  $\text{tr}_A$  and  $\text{tr}_S$  denote partial traces over the system and ancilla, respectively, it follows that

$$P(d) = \text{tr}_S(\rho_S E_d), \quad (13)$$

where

$$E_d = \text{tr}_A \left( (I \otimes \rho_A) U^\dagger (I \otimes \Pi_d) U \right) \quad (14)$$

is an operator acting on the Hilbert space of the original system. This proves half of what is needed, but it is also straightforward to go in the reverse direction—i.e., to show that for any POVM  $\{E_d\}$ , one can pick an ancilla and find operators  $\rho_A$ ,  $U$ , and  $\Pi_d$  such that Eq. (14) is true.

Putting this all together, there is a sense in which standard measurements capture everything that can be said about quantum measurement theory [50]. As became clear above, a way to think about this is that by learning something about the ancillary system through a standard measurement, one in turn learns something about the system of real interest. Indirect though it may seem, this can be a powerful technique, sometimes revealing information that could not have been revealed otherwise [51]. A very simple example is where a sender has only a single qubit available for the sending one of three potential messages. She therefore has a need to encode the message in one of three preparations of the system, even though the system is a two-state system. To recover as much information as possible, the receiver might (just intuitively) like to perform a measurement with three distinct outcomes. If, however, he were limited to a standard quantum measurement, he would only be able to obtain two outcomes. This—perhaps surprisingly—generally degrades his opportunities for recovery.

What I would like to bring up is whether this standard way of justifying the POVM is the most productive point of view one can take. Might any of the mysteries of quantum mechanics be alleviated by taking the POVM as a basic notion of measurement? Does the POVM’s utility portend a larger role for it in the foundations of quantum mechanics?

Standard Measurements	Generalized Measurements
$\{\Pi_i\}$ $\langle \psi   \Pi_i   \psi \rangle \geq 0, \forall  \psi\rangle$ $\sum_i \Pi_i = I$ $P(i) = \text{tr}(\rho \Pi_i)$ $\Pi_i \Pi_j = \delta_{ij} \Pi_i$	$\{E_d\}$ $\langle \psi   E_d   \psi \rangle \geq 0, \forall  \psi\rangle$ $\sum_d E_d = I$ $P(d) = \text{tr}(\rho E_d)$ <p style="text-align: center;">—————</p>

I try to make this point dramatic in my lectures by exhibiting a transparency of the table above. On the left-hand side there is a list of various properties for the standard notion of a quantum measurement. On the right-hand side, there is an almost identical list of properties for the POVMs. The only difference between the two columns is that the right-hand one is *missing* the orthonormality condition required of a standard measurement. The question I ask the audience is this: Does the addition of that one extra assumption really make the process of measurement any less mysterious? Indeed, I imagine myself teaching quantum mechanics for the first time and taking a vote with the best audience of all, the students. “Which set of postulates for quantum measurement would you prefer?” I am quite sure they would respond with a blank stare. But that



is the point! It would make no difference to them, and it should make no difference to us. The only issue worth debating is which notion of measurement will allow us to see more deeply into quantum mechanics.

Therefore let us pose the question that Gleason did, but with POVMs. In other words, let us suppose that the sum total of ways an experimenter can intervene on a quantum system corresponds to the full set of POVMs on its Hilbert space  $\mathcal{H}_D$ . It is the task of the theory to give him probabilities for the various consequences of his interventions. Concerning those probabilities, let us (in analogy to Gleason) assume only that whatever the probability for a given consequence  $E_c$  is, it does not depend upon whether  $E_c$  is associated with the POVM  $\{E_d\}$  or, instead, any other one  $\{\tilde{E}_d\}$ . This means we can assume there exists a function

$$f : \mathcal{E}_D \longrightarrow [0, 1], \quad (15)$$

where

$$\mathcal{E}_D = \left\{ E : 0 \leq \langle \psi | E | \psi \rangle \leq 1, \forall |\psi\rangle \in \mathcal{H}_D \right\}, \quad (16)$$

such that whenever  $\{E_d\}$  forms a POVM,

$$\sum_d f(E_d) = 1. \quad (17)$$

(In general, we will call any function satisfying

$$f(E) \geq 0 \quad \text{and} \quad \sum_d f(E_d) = \text{constant} \quad (18)$$

a *frame function*, in analogy to Gleason's nonnegative frame functions. The set  $\mathcal{E}_D$  is often called the set of *effects* over  $\mathcal{H}_D$ .)

It will come as no surprise, of course, that a Gleason-like theorem must hold for the function in Eq. (15). Namely, it can be shown that there must exist a density operator  $\rho$  for which

$$f(E) = \text{tr}(\rho E). \quad (19)$$

This was recently shown by Paul Busch [28] and, independently, by Joseph Renes and collaborators [29]. What *is* surprising however is the utter simplicity of the proof. Let us exhibit the whole thing right here and now.

First, consider the case where  $\mathcal{H}_D$  and the operators on it are defined *only* over the field of (complex) rational numbers. It is no problem to see that  $f$  is "linear" with respect to positive combinations of operators that never go outside  $\mathcal{E}_D$ . For consider a three-element POVM  $\{E_1, E_2, E_3\}$ . By assumption  $f(E_1) + f(E_2) + f(E_3) = 1$ . However, we can also group the first two elements in this POVM to obtain a new POVM, and must therefore have  $f(E_1 + E_2) + f(E_3) = 1$ . In other words, the function  $f$  must be additive with respect to a fine-graining operation:

$$f(E_1 + E_2) = f(E_1) + f(E_2). \quad (20)$$

Similarly for any two integers  $m$  and  $n$ ,

$$f(E) = m f\left(\frac{1}{m}E\right) = n f\left(\frac{1}{n}E\right) \quad (21)$$

Suppose  $\frac{n}{m} \leq 1$ . Then if we write  $E = nG$ , this statement becomes:

$$f\left(\frac{n}{m}G\right) = \frac{n}{m} f(G). \quad (22)$$

Thus we immediately have a kind of limited linearity on  $\mathcal{E}_D$ .

One *might* imagine using this property to cap off the theorem in the following way. Clearly the full  $D^2$ -dimensional vector space  $\mathcal{O}_D$  of Hermitian operators on  $\mathcal{H}_D$  is spanned by the set  $\mathcal{E}_D$  since that set contains, among other things, all the projection operators. Thus, we can write any operator  $E \in \mathcal{E}_D$  as a linear combination

$$E = \sum_{i=1}^{D^2} \alpha_i E_i \quad (23)$$

for some fixed operator-basis  $\{E_i\}_{i=1}^{D^2}$ . “Linearity” of  $f$  would then give

$$f(E) = \sum_{i=1}^{D^2} \alpha_i f(E_i). \quad (24)$$

So, if we define  $\rho$  by solving the  $D^2$  linear equations

$$\text{tr}(\rho E_i) = f(E_i), \quad (25)$$

we would have

$$f(E) = \sum_i \alpha_i \text{tr}(\rho E_i) = \text{tr}\left(\rho \sum_i \alpha_i E_i\right) = \text{tr}(\rho E) \quad (26)$$

and essentially be done. (Positivity and normalization of  $f$  would require  $\rho$  to be an actual density operator.) But the *problem* is that in expansion (23) there is no guarantee that the coefficients  $\alpha_i$  can be chosen so that  $\alpha_i E_i \in \mathcal{E}_D$ .

What remains to be shown is that  $f$  can be extended uniquely to a function that is truly linear on  $\mathcal{O}_D$ . This too is rather simple. First, take any positive semi-definite operator  $E$ . We can always find a positive rational number  $g$  such that  $E = gG$  and  $G \in \mathcal{E}_D$ . Therefore, we can simply define  $f(E) \equiv gf(G)$ . To see that this definition is unique, suppose there are two such operators  $G_1$  and  $G_2$  (with corresponding numbers  $g_1$  and  $g_2$ ) such that  $E = g_1 G_1 = g_2 G_2$ . Further suppose  $g_2 \geq g_1$ . Then  $G_2 = \frac{g_1}{g_2} G_1$  and, by the homogeneity of the original unextended definition of  $f$ , we obtain  $g_2 f(G_2) = g_1 f(G_1)$ . Furthermore this extension retains the additivity of the original function. For suppose that neither  $E$  nor  $G$ , though positive semi-definite, are necessarily in  $\mathcal{E}_D$ . We can find a positive rational number  $c \geq 1$  such that  $\frac{1}{c}(E+G)$ ,  $\frac{1}{c}E$ , and  $\frac{1}{c}G$  are all in  $\mathcal{E}_D$ . Then, by the rules we have already obtained,

$$f(E+G) = cf\left(\frac{1}{c}(E+G)\right) = cf\left(\frac{1}{c}E\right) + cf\left(\frac{1}{c}G\right) = f(E) + f(G). \quad (27)$$

Let us now further extend  $f$ 's domain to the full space  $\mathcal{O}_D$ . This can be done by noting that any operator  $H$  can be written as the difference  $H = E - G$  of two positive semi-definite operators. Therefore define  $f(H) \equiv f(E) - f(G)$ , from which it also follows that  $f(-G) = -f(G)$ . To see that this definition is unique suppose there are four operators  $E_1$ ,  $E_2$ ,  $G_1$ , and  $G_2$ , such that  $H = E_1 - G_1 = E_2 - G_2$ . It follows that  $E_1 + G_2 = E_2 + G_1$ . Applying  $f$  (as extended in the previous paragraph) to this equation, we obtain  $f(E_1) + f(G_2) = f(E_2) + f(G_1)$  so that  $f(E_1) - f(G_1) = f(E_2) - f(G_2)$ . Finally, with this new extension, full linearity can be checked immediately. This completes the proof as far as the (complex) rational number field is concerned: Because  $f$  extends uniquely to a linear functional on  $\mathcal{O}_D$ , we can indeed go through the steps of Eqs. (23) through (26) without worry.

There are two things that are significant about this much of the proof. First, in contrast to Gleason's original theorem, there is nothing to bar the same logic from working when  $D = 2$ . This is quite nice because much of the community has gotten into the habit of thinking that

there is nothing particularly “quantum mechanical” about a single qubit. [52] Indeed, because orthogonal projectors on  $\mathcal{H}_2$  can be mapped onto antipodes of the Bloch sphere, it is known that the measurement-outcome statistics for any standard measurement can be mocked-up through a noncontextual hidden-variable theory. What this result shows is that that simply is not the case when one considers the full set of POVMs as one’s potential measurements.<sup>20</sup>

The other important thing is that the theorem works for Hilbert spaces over the rational number field: one does not need to invoke the full power of the continuum. This contrasts with the surprising result of Meyer [54] that the standard Gleason theorem fails in such a setting. The present theorem hints at a kind of resiliency to the structure of quantum mechanics that falls through the mesh of the standard Gleason result: The probability rule for POVMs does not actually depend so much upon the detailed workings of the number field.

The final step of the proof, indeed, is to show that nothing goes awry when we go the extra step of reinstating the continuum.

In other words, we need to show that the function  $f$  (now defined on the set  $\mathcal{E}_{\mathbb{D}}$  of complex operators) is a continuous function. This comes about in a simple way from  $f$ ’s additivity. Suppose for two positive semi-definite operators  $E$  and  $G$  that  $E \leq G$  (i.e.,  $G - E$  is positive semi-definite). Then trivially there exists a positive semi-definite operator  $H$  such that  $E + H = G$  and through which the additivity of  $f$  gives  $f(E) \leq f(G)$ . Let  $c$  be an irrational number, and let  $a_n$  be an increasing sequence and  $b_n$  a decreasing sequence of rational numbers that both converge to  $c$ . It follows for any positive semi-definite operator  $E$ , that

$$f(a_n E) \leq f(cE) \leq f(b_n E) , \tag{28}$$

which implies

$$a_n f(E) \leq f(cE) \leq b_n f(E) . \tag{29}$$

Since  $\lim a_n f(E)$  and  $\lim b_n f(E)$  are identical, by the “pinching theorem” of elementary calculus, they must equal  $f(cE)$ . This establishes that we can consistently define

$$f(cE) = cf(E) . \tag{30}$$

Reworking the extensions of  $f$  in the last inset (but with this enlarged notion of homogeneity), one completes the proof in a straightforward manner.

Of course we are not getting something from nothing. The reason the present derivation is so easy in contrast to the standard proof is that *mathematically* the assumption of POVMs as the basic notion of measurement is significantly stronger than the usual assumption. *Physically*, though, I would say it is just the opposite. Why add extra restrictions to the notion of measurement when they only make the route from basic assumption to practical usage more circuitous than need be?

Still, no assumption should be left unanalyzed if it stands a chance of bearing fruit. Indeed, one can ask what is so very compelling about the noncontextuality property (of probability assignments) that both Gleason’s original theorem and the present version make use of. Given the picture of measurement as a kind of invasive intervention into the world, one might expect the very opposite. One is left wondering why measurement probabilities do not depend upon the whole context of the measurement interaction. Why is  $P(d)$  not of the form  $f(d, \{E_c\})$ ? Is there any good reason for this kind of assumption?

---

<sup>20</sup>In fact, one need not consider the full set of POVMs in order to derive a noncolorability result along the lines of Kochen and Specker for a single qubit. Considering only 3-outcome POVMs of the so-called “trine” or “Mercedes-Benz” type already does the trick. [53]

## 4.1 Noncontextuality

In point of fact, there is: For, one can argue that the noncontextuality of probability assignments for measurement outcomes is more basic than even the particular structure of measurements (i.e., that they be POVMs). Noncontextuality bears more on how we identify what we are measuring than anything to do with a measurement’s invasiveness upon nature.

Here is a way to see that. [55] Forget about quantum mechanics for the moment and consider a more general world—one that, skipping the details of quantum mechanics, still retains the notions of systems, machines, actions, and consequences, and, most essentially, retains the notion of a scientific agent performing those actions and taking note of those consequences.

Take a system  $S$  and imagine acting on it with one of two machines,  $M$  and  $N$ —things that we might colloquially call “measurement devices” if we had the aid of a theory like quantum mechanics. For the case of machine  $M$ , let us label the possible consequences of that action  $\{m_1, m_2, \dots\}$ . (Or if you want to think of them in the mold of quantum mechanics, call them “measurement outcomes.”) For the case of machine  $N$ , let us label them  $\{n_1, n_2, \dots\}$ .

If one takes a Bayesian point of view about probability, then nothing can stop the agents in this world from using all the information available to them to ascribe probabilities to the consequences of those two potential actions. Thus, for an agent who cares to take note, there are two probability distributions,  $p_M(m_k)$  and  $p_N(n_k)$ , lying around. These probability distributions stand for *his* subjective judgments about what will obtain if he acts with either of the two machines.

This is well and good, but it is hardly a physical theory. We need more. Let us suppose the labels  $m_k$  and  $n_k$  are, at the very least, to be identified with elements in some master set  $\mathcal{F}$ —that is, that there is some kind of connective glue for comparing the operation of one machine to another. This set may even be a set with further structure, like a vector space or something, but that is beside the point. What is of first concern is under what conditions will an agent identify two particular labels  $m_i$  and  $n_j$  with the same element  $F$  in the master set—disparate in appearance, construction, and history though the two machines  $M$  and  $N$  may be. Perhaps one machine was manufactured by Lucent Technologies while the other was manufactured by IBM Corporation.

There is really only one tool available for the purpose, namely the probability assignments  $p_M(m_i)$  and  $p_N(n_j)$ . If

$$p_M(m_i) \neq p_N(n_j), \quad (31)$$

then surely he would not imagine identifying  $m_i$  and  $n_j$  with the same element  $F \in \mathcal{F}$ . If, on the other hand, he finds

$$p_M(m_i) = p_N(n_j) \quad (32)$$

*regardless* of his initial beliefs about  $S$ , then we might think there is some warrant for it.

That is the whole story of noncontextuality. It is nothing more than: The consequences ( $m_i$  and  $n_j$ ) of our disparate actions ( $M$  and  $N$ ) should be labeled the same when we would bet the same on them in all possible circumstances (i.e., regardless of our initial knowledge of  $S$ ). To put this maybe a bit more baldly, the label by which we identify a measurement outcome is a subjective judgment just like a probability, and just like a quantum state.

By this point of view, noncontextuality is a tautology—it is built in from the start. Asking why we have it is a waste of time. Where we do have a freedom is in asking why we make one particular choice of a master set over another. Asking that may tell us something about physics. Why should the  $m_i$ ’s be drawn from a set of effects  $\mathcal{E}_D$ ? Not all choices of the master set are equally interesting once we have settled on noncontextuality for the probability assignments.<sup>21</sup> But quantum mechanics, of course, is particularly interesting!

<sup>21</sup>See Ref. [56], pp. 86–88, and Ref. [57] for some examples in that regard.

## 4.2 Le Bureau International des Poids et Mesures à Paris

There is still one further, particularly important, advantage to thinking of POVMs as the basic notion of measurement in quantum mechanics. For with an appropriately chosen *single* POVM one can stop thinking of the quantum state as a linear operator altogether, and instead start thinking of it as a probabilistic judgment with respect to the (potential) outcomes of a *standard quantum measurement*. That is, a measurement device right next to the standard kilogram and the standard meter in a carefully guarded vault, deep within the bowels of the International Bureau of Weights and Measures.<sup>22</sup> Here is what I mean by this.

Our problem hinges on finding a measurement for which the probabilities of outcomes completely specify a unique density operator. Such measurements are called *informationally complete* and have been studied for some time [60, 61, 62]. Here however, the picture is most pleasing if we consider a slightly refined version of the notion—that of the *minimal* informationally complete measurement [32]. The space of Hermitian operators on  $\mathcal{H}_D$  is itself a linear vector space of dimension  $D^2$ . The quantity  $\text{tr}(A^\dagger B)$  serves as an inner product on that space. Hence, if we can find a POVM  $\mathcal{E} = \{E_d\}$  consisting of  $D^2$  linearly independent operators, the probabilities  $P(d) = \text{tr}(\rho E_d)$ —now thought of as *projections* in the directions of the vectors  $E_d$ —will completely specify the operator  $\rho$ . Any two distinct density operators  $\rho$  and  $\sigma$  must give rise to distinct outcome statistics for this measurement. The minimal number of outcomes a POVM can have and still be informationally complete is  $D^2$ .

Do minimal informationally complete POVMs exist? The answer is yes. Here is a simple way to produce one, though there are many other ways. Start with a complete orthonormal basis  $|e_j\rangle$  on  $\mathcal{H}_D$ . It is easy to check that the following  $D^2$  rank-1 projectors  $\Pi_d$  form a linearly independent set.

1. For  $d = 1, \dots, D$ , let

$$\Pi_d = |e_j\rangle\langle e_j|, \quad (33)$$

where  $j$ , too, runs over the values  $1, \dots, D$ .

2. For  $d = D + 1, \dots, \frac{1}{2}D(D + 1)$ , let

$$\Pi_d = \frac{1}{2}(|e_j\rangle + |e_k\rangle)(\langle e_j| + \langle e_k|), \quad (34)$$

where  $j < k$ .

3. Finally, for  $d = \frac{1}{2}D(D + 1) + 1, \dots, D^2$ , let

$$\Pi_d = \frac{1}{2}(|e_j\rangle + i|e_k\rangle)(\langle e_j| - i\langle e_k|), \quad (35)$$

where again  $j < k$ .

All that remains is to transform these (positive-semidefinite) linearly independent operators  $\Pi_d$  into a proper POVM. This can be done by considering the positive semidefinite operator  $G$  defined by

$$G = \sum_{d=1}^{D^2} \Pi_d. \quad (36)$$

---

<sup>22</sup>This idea has its roots in L. Hardy's two important papers Refs. [58] and [59].

It is straightforward to show that  $\langle \psi | G | \psi \rangle > 0$  for all  $|\psi\rangle \neq 0$ , thus establishing that  $G$  is positive definite (i.e., Hermitian with positive eigenvalues) and hence invertible. Applying the (invertible) linear transformation  $X \rightarrow G^{-1/2} X G^{-1/2}$  to Eq. (36), we find a valid decomposition of the identity,

$$I = \sum_{d=1}^{D^2} G^{-1/2} \Pi_d G^{-1/2} . \quad (37)$$

The operators

$$E_d = G^{-1/2} \Pi_d G^{-1/2} \quad (38)$$

satisfy the conditions of a POVM, Eqs. (6) and (7), and moreover, they retain the rank and linear independence of the original  $\Pi_d$ . Thus we have what we need.

With the existence of minimal informationally complete POVMs assured, we can think about the vault in Paris. Let us suppose from here out that it contains a machine that enacts a minimal informationally complete POVM  $E_h$  whenever it is used. We reserve the index  $h$  to denote the outcomes of this standard quantum measurement, for they will replace the notion of the ‘‘hypothesis’’ in classical statistical theory. Let us develop this from a Bayesian point of view.

Whenever one has a quantum system in mind, it is legitimate for him to use all he knows and believes of it to ascribe a probability function  $P(h)$  to the (potential) outcomes of this standard measurement. In fact, that is all a quantum state *is* from this point of view: It is a subjective judgment about which consequence will obtain as a result of an interaction between *one’s* system and *that* machine. Whenever one performs a measurement  $\{E_d\}$  on the system—one different from the standard quantum measurement  $\{E_h\}$ —at the most basic level of understanding, all one is doing is gathering (or evoking) a piece of data  $d$  that (among other things) allows one to update from one’s initial subjective judgment  $P(h)$  to *something* else  $P_d(h)$ .<sup>23</sup>

What is important to recognize is that, with this change of description, we may already be edging toward a piece of quantum mechanics that is not of information theoretic origin. It is this. If one accepts quantum mechanics and supposes that one has a system for which the standard quantum measurement device has  $D^2$  outcomes (for some integer  $D$ ), then one is no longer completely free to make just any subjective judgment  $P(h)$  he pleases. There are constraints. Let us call the allowed region of initial judgments  $\mathcal{P}_{\text{SQM}}$ .

For instance, take the POVM in Eq. (38) as the standard quantum measurement. (And thus, now label its outcomes by  $h$  rather than  $d$ .) Then, one can show that  $P(h)$  is bounded away from unity, regardless of one’s initial quantum state for the system. In particular,

$$\begin{aligned} P(h) &\leq \max_{\rho} \text{tr}(\rho E_h) \\ &\leq \max_{\Pi} \text{tr}(\Pi E_h) \\ &\leq \lambda_{\max}(E_h) \\ &= \lambda_{\max}(G^{-1/2} \Pi_h G^{-1/2}) = \lambda_{\max}(\Pi_h G^{-1} \Pi_h) \\ &\leq \lambda_{\max}(G^{-1}) , \end{aligned} \quad (39)$$

where the second line above refers to a maximization over all one dimensional projectors and  $\lambda_{\max}(\cdot)$  denotes the largest eigenvalue of its argument. On the other hand, one can calculate the eigenvalues of  $G^{-1}$  explicitly. [63] Through this, one obtains

$$P(h) \leq \left[ D - \frac{1}{2} \left( 1 + \cot \frac{3\pi}{4D} \right) \right]^{-1} < 1 . \quad (40)$$

---

<sup>23</sup>We will come back to describing the precise form of this update and its similarity to Bayes’ rule in Section 6.

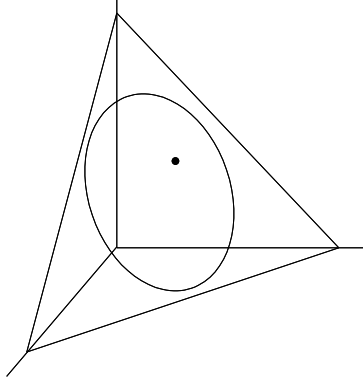

Figure 1: The planar surface represents the space of all probability distributions over  $D^2$  outcomes. Accepting quantum mechanics is, in part, accepting that one’s subjective beliefs for the outcomes of a standard quantum measurement device will not fall outside a certain convex set. Each point within the region represents a perfectly valid quantum state.

For large  $D$ , this bound asymptotes to roughly  $(0.79D)^{-1}$ .

More generically, for any minimal informationally complete POVM  $\{E_h\}$ ,  $P(h)$  must be bounded away from unity for all its possible outcomes. Thus even at this stage, there is something driving a wedge between quantum mechanics and simple Bayesian probability theory. When one accepts quantum mechanics, one voluntarily accepts a restriction on one’s subjective judgments for the consequences of a standard quantum measurement intervention: For all consequences  $h$ , there are no conditions whatsoever convincing enough to compel one to a probability ascription  $P(h) = 1$ . That is, one gives up on the hope of certainty. This, indeed, one might pinpoint as an assumption about the physical world that goes beyond pure probability theory.<sup>24</sup>

But what is that assumption in physical terms? What is our best description of the wedge? Some think they already know the answer, and it is quantum entanglement.

## 5 Wither Entanglement?<sup>25</sup>

When two systems, of which we know the states by their respective representatives, enter into temporary physical interaction due to known forces between them, and when after a time of mutual influence the systems separate again, then they can no longer be described in the same way as before, viz. by endowing each of them with a representative of its own. I would not call that *one* but rather *the* characteristic trait of quantum mechanics, the one that enforces its entire departure from classical lines of thought. By the interaction the two representatives (or  $\psi$ -functions) have become entangled.

— Erwin Schrödinger, 1935

<sup>24</sup>It is at this point that the present account of quantum mechanics differs most crucially from Refs. [58] and [59]. Hardy sees quantum mechanics as a generalization and extension of classical probability theory, whereas quantum mechanics is depicted here as a restriction to probability theory. It is a restriction that takes into account how we ought to think and gamble in light of a certain physical fact—a fact we are working like crazy to identify.

<sup>25</sup>This is not a spelling mistake.

Quantum entanglement has certainly captured the attention of our community. By most accounts it is the main ingredient in quantum information theory and quantum computing [64], and it is the main mystery of the quantum foundations [65]. But what is it? Where does it come from?

The predominant purpose it has served in this paper has been as a kind of background. For it, more than any other ingredient in quantum mechanics, has clinched the issue of “information about what?” in the author’s mind: That information cannot be about a preexisting reality (a hidden variable) unless we are willing to renege on our reason for rejecting the quantum state’s objective reality in the first place. What I am alluding to here is the conjunction of the Einstein argument reported in Section 3 and the phenomena of the Bell inequality violations by quantum mechanics. Putting those points together gave us that the information symbolized by a  $|\psi\rangle$  must be information about the potential consequences of our interventions into the world.

But, now I would like to turn the tables and ask whether the structure of our potential interventions—the POVMs—can tell us something about the origin of entanglement. Could it be that the concept of entanglement is just a minor addition to the much deeper point that measurements have this structure?

The technical translation of this question is, why do we combine systems according to the tensor-product rule? There are certainly innumerable ways to combine two Hilbert spaces  $\mathcal{H}_A$  and  $\mathcal{H}_B$  to obtain a third  $\mathcal{H}_{AB}$ . We could take the direct sum of the two spaces  $\mathcal{H}_{AB} = \mathcal{H}_A \oplus \mathcal{H}_B$ . We could take their Grassmann product  $\mathcal{H}_{AB} = \mathcal{H}_A \wedge \mathcal{H}_B$  [66]. We could take scads of other things. But instead we take their tensor product,

$$\mathcal{H}_{AB} = \mathcal{H}_A \otimes \mathcal{H}_B . \tag{41}$$

Why?

Could it arise from the selfsame considerations as of the previous section—namely, from a noncontextuality property for measurement-outcome probabilities? The answer is yes, and the theorem I am about demonstrate owes much in inspiration to Ref. [67].<sup>26</sup>

Here is the scenario. Suppose we have two quantum systems, and we can make a measurement on each. On the first, we can measure any POVM on the  $D_A$ -dimensional Hilbert space  $\mathcal{H}_A$ ; on the second, we can measure any POVM on the  $D_B$ -dimensional Hilbert space  $\mathcal{H}_B$ . (This, one might think, is the very essence of having *two* systems rather than one—i.e., that we can probe them independently.) Moreover, suppose we may condition the second measurement on the nature and the outcome of the first, and vice versa. That is to say—walking from  $A$  to  $B$ —we could first measure  $\{E_i\}$  on  $A$ , and then, depending on the outcome  $i$ , measure  $\{F_j^i\}$  on  $B$ . Similarly—walking from  $B$  to  $A$ —we could first measure  $\{F_j\}$  on  $B$ , and then, depending on the outcome  $j$ , measure  $\{E_i^j\}$  on  $A$ . So that we have valid POVMs, we must have

$$\sum_i E_i = I \quad \text{and} \quad \sum_j F_j^i = I \quad \forall i , \tag{42}$$

and

$$\sum_i E_i^j = I \quad \forall j \quad \text{and} \quad \sum_j F_j = I , \tag{43}$$

for these sets of operators. Let us denote by  $S_{ij}$  an *ordered pair* of operators, either of the form  $(E_i, F_j^i)$  or of the form  $(E_i^j, F_j)$ , as appearing above. Let us call a set of such operators  $\{S_{ij}\}$  a *locally-measurable POVM tree*.

---

<sup>26</sup>After posting Ref. [1], Howard Barnum and Alex Wilce brought to my attention that there is a significant amount of literature in the quantum logic community devoted to similar ways of motivating the tensor-product rule. See for example Ref. [68] and the many citations therein.



Suppose now that—just as with the POVM-version of Gleason’s theorem in Section 4—the joint probability  $P(i, j)$  for the outcomes of such a measurement should not depend upon which tree  $S_{ij}$  is embedded in: This is essentially the same assumption we made there, but now applied to local measurements on the separate systems. In other words, let us suppose there exists a function

$$f : \mathcal{E}_{D_A} \times \mathcal{E}_{D_B} \longrightarrow [0, 1] \quad (44)$$

such that

$$\sum_{ij} f(S_{ij}) = 1 \quad (45)$$

whenever the  $S_{ij}$  satisfy either Eq. (42) or Eq. (43).

Note in particular that Eq. (44) makes no use of the tensor product: The domain of  $f$  is the *Cartesian product* of the two sets  $\mathcal{E}_{D_A}$  and  $\mathcal{E}_{D_B}$ . The notion of a *local* measurement on the separate systems is enforced by the requirement that the ordered pairs  $S_{ij}$  satisfy the side conditions of Eqs. (42) and (43). This, of course, is not the most general kind of local measurement one can imagine—more sophisticated measurements could involve multiple ping-pongings between  $A$  and  $B$  as in Ref. [69]—but the present restricted class is already sufficient for fixing that the probability rule for local measurements must come from a tensor-product structure.

The *theorem*<sup>27</sup> is this: If  $f$  satisfies Eqs. (44) and (45) for all locally-measurable POVM trees, then there exists a linear operator  $\mathcal{L}$  on  $\mathcal{H}_A \otimes \mathcal{H}_B$  such that

$$f(E, F) = \text{tr}(\mathcal{L}(E \otimes F)) . \quad (46)$$

If  $\mathcal{H}_A$  and  $\mathcal{H}_B$  are defined over the field of complex numbers, then  $\mathcal{L}$  is unique. Uniqueness does not hold, however, if the underlying field is the real numbers.

The proof of this statement is almost a trivial extension of the proof in Section 4. One again starts by showing additivity, but this time in the two variables  $E$  and  $F$  separately. For instance, for a fixed  $E \in \mathcal{E}_{D_A}$ , define

$$g_E(F) = f(E, F) , \quad (47)$$

and consider two locally-measurable POVM trees

$$\{(I - E, F_i), (E, G_\alpha)\} \quad \text{and} \quad \{(I - E, F_i), (E, H_\beta)\} , \quad (48)$$

where  $\{F_i\}$ ,  $\{G_\alpha\}$ , and  $\{H_\beta\}$  are arbitrary POVMs on  $\mathcal{H}_B$ . Then Eq. (45) requires that

$$\sum_i g_{I-E}(F_i) + \sum_\alpha g_E(G_\alpha) = 1 \quad (49)$$

and

$$\sum_i g_{I-E}(F_i) + \sum_\beta g_E(H_\beta) = 1 . \quad (50)$$

From this it follows that,

$$\sum_\alpha g_E(G_\alpha) = \sum_\beta g_E(H_\beta) = \text{const.} \quad (51)$$

That is to say,  $g_E(F)$  is a frame function in the sense of Section 4. Consequently, we know that we can use the same methods as there to uniquely extend  $g_E(F)$  to a linear functional on the complete set of Hermitian operators on  $\mathcal{H}_B$ . Similarly, for fixed  $F \in \mathcal{E}_{D_B}$ , we can define

$$h_F(E) = f(E, F) , \quad (52)$$

---

<sup>27</sup>In Ref. [1], a significantly stronger claim is made: Namely, that  $\mathcal{L}$  is in fact a density operator. This was a flat-out mistake. See further discussion below.

and prove that this function too can be extended uniquely to a linear functional on the Hermitian operators on  $\mathcal{H}_A$ .

The linear extensions of  $g_E(F)$  and  $h_F(E)$  can be put together in a simple way to give a full bilinear extension to the function  $f(E, F)$ . Namely, for any two Hermitian operators  $A$  and  $B$  on  $\mathcal{H}_A$  and  $\mathcal{H}_B$ , respectively, let  $A = \alpha_1 E_1 - \alpha_2 E_2$  and  $B = \beta_1 F_1 - \beta_2 F_2$  be decompositions such that  $\alpha_1, \alpha_2, \beta_1, \beta_2 \geq 0$ ,  $E_1, E_2 \in \mathcal{E}_{D_A}$ , and  $F_1, F_2 \in \mathcal{E}_{D_B}$ . Then define

$$f(A, B) \equiv \alpha_1 g_{E_1}(B) - \alpha_2 g_{E_2}(B) . \quad (53)$$

To see that this definition is unique, take any other decomposition

$$A = \tilde{\alpha}_1 \tilde{E}_1 - \tilde{\alpha}_2 \tilde{E}_2 . \quad (54)$$

Then we have

$$\begin{aligned} f(A, B) &= \tilde{\alpha}_1 g_{\tilde{E}_1}(B) - \tilde{\alpha}_2 g_{\tilde{E}_2}(B) \\ &= \tilde{\alpha}_1 f(\tilde{E}_1, B) - \tilde{\alpha}_2 f(\tilde{E}_2, B) \\ &= \beta_1 (\tilde{\alpha}_1 f(\tilde{E}_1, F_1) - \tilde{\alpha}_2 f(\tilde{E}_2, F_1)) - \beta_2 (\tilde{\alpha}_1 f(\tilde{E}_1, F_2) - \tilde{\alpha}_2 f(\tilde{E}_2, F_2)) \\ &= \beta_1 h_{F_1}(A) - \beta_2 h_{F_2}(A) \\ &= \beta_1 (\alpha_1 f(E_1, F_1) - \alpha_2 f(E_2, F_1)) - \beta_2 (\alpha_1 f(E_1, F_2) - \alpha_2 f(E_2, F_2)) \\ &= \alpha_1 f(E_1, B) - \alpha_2 f(E_2, B) \\ &= \alpha_1 g_{E_1}(B) - \alpha_2 g_{E_2}(B) , \end{aligned} \quad (55)$$

which is as desired.

With bilinearity for the function  $f$  established, we have essentially the full story [66, 70]. For, let  $\{E_i\}$ ,  $i = 1, \dots, D_A^2$ , be a complete basis for the Hermitian operators on  $\mathcal{H}_A$  and let  $\{F_j\}$ ,  $j = 1, \dots, D_B^2$ , be a complete basis for the Hermitian operators on  $\mathcal{H}_B$ . If  $E = \sum_i \alpha_i E_i$  and  $F = \sum_j \beta_j F_j$ , then

$$f(E, F) = \sum_{ij} \alpha_i \beta_j f(E_i, F_j) . \quad (56)$$

Define  $\mathcal{L}$  to be a linear operator on  $\mathcal{H}_A \otimes \mathcal{H}_B$  satisfying the  $(D_A D_B)^2$  linear equations

$$\text{tr}(\mathcal{L}(E_i \otimes F_j)) = f(E_i, F_j) . \quad (57)$$

Such an operator always exists. Consequently we have,

$$\begin{aligned} f(E, F) &= \sum_{ij} \alpha_i \beta_j \text{tr}(\mathcal{L}(E_i \otimes F_j)) \\ &= \text{tr}(\mathcal{L}(E \otimes F)) . \end{aligned} \quad (58)$$

For complex Hilbert spaces  $\mathcal{H}_A$  and  $\mathcal{H}_B$ , the uniqueness of  $\mathcal{L}$  follows because the set  $\{E_i \otimes F_j\}$  forms a complete basis for the Hermitian operators on  $\mathcal{H}_A \otimes \mathcal{H}_B$ . [71] For real Hilbert spaces, however, the analog of the Hermitian operators are the symmetric operators. The dimensionality of the space of symmetric operators on a real Hilbert space  $\mathcal{H}_D$  is  $\frac{1}{2}D(D+1)$ , rather than the  $D^2$  it is for the complex case. This means that in the steps above only

$$\frac{1}{4} D_A D_B (D_A + 1)(D_B + 1) \quad (59)$$

equations will appear in Eq. (57), whereas

$$\frac{1}{2}D_A D_B (D_A D_B + 1) \tag{60}$$

are needed to uniquely specify an  $\mathcal{L}$ . For instance take  $D_A = D_B = 2$ . Then Eq. (59) gives nine equations, while Eq. (60) requires ten.

This establishes the theorem. It would be nice if we could go further and establish the full probability rule for local quantum measurements—i.e., that  $\mathcal{L}$  must be a density operator. Unfortunately, our assumptions are not strong enough for that. Here is a counterexample. [72] Consider a linear operator that is proportional to the swap operator on the two Hilbert spaces:

$$\mathcal{L}_s(E \otimes F) = \frac{1}{D^2} F \otimes E. \tag{61}$$

This clearly satisfies the conditions of our theorem, but it is not equivalent to a density operator.

Of course, one could recover positivity for  $\mathcal{L}$  by requiring that it give positive probabilities even for nonlocal measurements (i.e., resolutions of the identity operator on  $\mathcal{H}_A \otimes \mathcal{H}_B$ ). But in the purely local setting contemplated here, that would be a cheap way out. For, one should ask in good conscience what ought to be the rule for defining the full class of measurements (including nonlocal measurements): Why should it correspond to an arbitrary resolution of the identity on the tensor product? There is nothing that makes it obviously so, unless one has already accepted standard quantum mechanics.

Alternatively, it must be possible to give a purely local condition that will restrict  $\mathcal{L}$  to be a density operator. This is because  $\mathcal{L}$ , as noted above, is uniquely determined by the function  $f(E, F)$ ; we never need to look further than the probabilities of local measurements outcomes in specifying  $\mathcal{L}$ . Ferreting out such a condition supplies an avenue for future research.

All of this does not, however, take away from the fact that whatever  $\mathcal{L}$  is, it must be a linear operator on the tensor product of  $\mathcal{H}_A$  and  $\mathcal{H}_B$ . Therefore, let us close by emphasizing the striking feature of this way of deriving the tensor-product rule for combining separate quantum systems: It is built on the very concept of local measurement. There is nothing “spooky” or “nonlocal” about it; there is nothing in it resembling “passion at a distance” [73]. Indeed, one did not even have to consider probability assignments for the outcomes of measurements of the “nonlocality without entanglement” variety [69] to uniquely fix the probability rule. That is—to give an example on  $\mathcal{H}_3 \otimes \mathcal{H}_3$ —one need not consider standard measurements like  $\{E_d = |\psi_d\rangle\langle\psi_d|\}$ ,  $d = 1, \dots, 9$ , where

$$\begin{aligned} |\psi_1\rangle &= |1\rangle|1\rangle \\ |\psi_2\rangle &= |0\rangle|0+1\rangle & |\psi_6\rangle &= |1+2\rangle|0\rangle \\ |\psi_3\rangle &= |0\rangle|0-1\rangle & |\psi_7\rangle &= |1-2\rangle|0\rangle \\ |\psi_4\rangle &= |2\rangle|1+2\rangle & |\psi_8\rangle &= |0+1\rangle|2\rangle \\ |\psi_5\rangle &= |2\rangle|1-2\rangle & |\psi_9\rangle &= |0-1\rangle|2\rangle \end{aligned} \tag{62}$$

with  $|0\rangle$ ,  $|1\rangle$ , and  $|2\rangle$  forming an orthonormal basis on  $\mathcal{H}_3$ , and  $|0+1\rangle = \frac{1}{\sqrt{2}}(|0\rangle + |1\rangle)$ , etc. This is a measurement that takes neither the form of Eq. (42) nor (43). It stands out instead, in that even though all its POVM elements are tensor-product operators—i.e., they have no quantum entanglement—it still *cannot* be measured by local means, even with the elaborate ping-ponging strategies mentioned earlier.

Thus, the tensor-product rule, and with it quantum entanglement, seems to be more a statement of locality than anything else. It, like the probability rule, is more a product of the structure of the

observables—that they are POVMs—combined with noncontextuality. In searching for the secret ingredient to drive a wedge between general Bayesian probability theory and quantum mechanics, it seems that the direction *not* to look is toward quantum entanglement. Perhaps the trick instead is to dig deeper into the Bayesian toolbox.

## 6 Whither Bayes’ Rule? <sup>28</sup>

And so you see I have come to doubt  
 All that I once held as true  
 I stand alone without beliefs  
 The only truth I know is you.

— *Paul Simon*, timeless

Quantum states are states of information, knowledge, belief, pragmatic gambling commitments, *not* states of nature. That statement is the cornerstone of this paper. Thus, in searching to make sense of the remainder of quantum mechanics, one strategy ought to be to seek guidance [74] from the most developed avenue of “rational-decision theory” to date—Bayesian probability theory [75, 76, 77]. Indeed, the very aim of Bayesian theory is to develop reliable methods of reasoning and making decisions in the light of incomplete information. To what extent does that structure mesh with the seemingly independent structure of quantum mechanics? To what extent are there analogies; to what extent distinctions?

This section is about turning a distinction into an analogy. The core of the matter is the manner in which states of belief are updated in the two theories. At first sight, they appear to be quite different in character. To see this, let us first explore how quantum mechanical states change when information is gathered.

In older accounts of quantum mechanics, one often encounters the “collapse postulate” as a basic statement of the theory. One hears things like, “Axiom 5: Upon the completion of an ideal measurement of an Hermitian operator  $H$ , the system is left in an eigenstate of  $H$ .” In quantum information, however, it has become clear that it is useful to broaden the notion of measurement, and with it, the analysis of how a state can change in the process. The foremost reason for this is that the collapse postulate is simply not true in general: Depending upon the exact nature of the measurement interaction, there may be any of a large set of possibilities for the final state of a system.

The broadest consistent notion of state change arises in the theory of “effects and operations” [50]. The statement is this. Suppose one’s initial state for a quantum system is a density operator  $\rho$ , and a POVM  $\{E_d\}$  is measured on that system. Then, according to this formalism, the state after the measurement can be *any* state  $\rho_d$  of the form

$$\rho_d = \frac{1}{\text{tr}(\rho E_d)} \sum_i A_{di} \rho A_{di}^\dagger, \tag{63}$$

where

$$\sum_i A_{di}^\dagger A_{di} = E_d. \tag{64}$$

Note the immense generality of this formula. There is no constraint on the number of indices  $i$  in the  $A_{di}$  and these operators need not even be Hermitian.

---

<sup>28</sup>This is not a spelling mistake.

The *usual* justification for this kind of generality—just as in the case of the commonplace justification for the POVM formalism—comes about by imagining that the measurement arises in an indirect fashion rather than as a direct and immediate observation. In other words, the primary system is pictured to interact with an ancilla first, and only then subjected to a “real” measurement on the ancilla alone. The trick is that one posits a kind of projection postulate on the primary system due to this process. This assumption has a much safer feel than the raw projection postulate since, after the interaction, no measurement on the ancilla should cause a physical perturbation to the primary system.

More formally, we can start out by following Eqs. (9) and (10), but in place of Eq. (11) we must make an assumption on how the system’s state changes. For this one invokes a kind of “projection-postulate-at-a-distance.”<sup>29</sup> Namely, one takes

$$\rho_d = \frac{1}{P(d)} \operatorname{tr}_A \left( (I \otimes \Pi_d) U (\rho_S \otimes \rho_A) U^\dagger (I \otimes \Pi_d) \right). \quad (65)$$

The reason for invoking the partial trace is to make sure that any hint of a state change for the ancilla remains unaddressed.

To see how expression (65) makes connection to Eq. (63), denote the eigenvalues and eigenvectors of  $\rho_A$  by  $\lambda_\alpha$  and  $|a_\alpha\rangle$  respectively. Then  $\rho_S \otimes \rho_A$  can be written as

$$\rho_S \otimes \rho_A = \sum_\alpha \sqrt{\lambda_\alpha} |a_\alpha\rangle \rho_S \langle a_\alpha| \sqrt{\lambda_\alpha}, \quad (66)$$

and, expanding Eq. (65), we have

$$\begin{aligned} \rho_d &= \frac{1}{P(d)} \sum_\beta \langle a_\beta | (I \otimes \Pi_d) U^\dagger (\rho_S \otimes \rho_A) U (I \otimes \Pi_d) | a_\beta \rangle \\ &= \frac{1}{P(d)} \sum_{\alpha\beta} \left( \sqrt{\lambda_\alpha} \langle a_\beta | (I \otimes \Pi_d) U^\dagger | a_\alpha \rangle \right) \rho_S \left( \langle a_\alpha | U (I \otimes \Pi_d) | a_\beta \rangle \sqrt{\lambda_\alpha} \right). \end{aligned} \quad (67)$$

A representation of the form in Eq. (63) can be made by taking

$$A_{b\alpha\beta} = \sqrt{\lambda_\alpha} \langle a_\alpha | U (I \otimes \Pi_d) | a_\beta \rangle \quad (68)$$

and lumping the two indices  $\alpha$  and  $\beta$  into the single index  $i$ . Indeed, one can easily check that Eq. (64) holds.<sup>30</sup> This completes what we had set out to show. However, just as with the case of the POVM  $\{E_d\}$ , one can always find a way to reverse engineer the derivation: Given a set of  $A_{di}$ , one can always find a  $U$ , a  $\rho_A$ , and set of  $\Pi_d$  such that Eq. (65) becomes true.

Of course the old collapse postulate is contained within the extended formalism as a special case: There, one just takes both sets  $\{E_d\}$  and  $\{A_{di} = E_d\}$  to be sets of orthogonal projection operators. Let us take a moment to think about this special case in isolation. What is distinctive about it is that it captures in the extreme a common folklore associated with the measurement process. For it tends to convey the image that measurement is a kind of gut-wrenching violence: In one moment the state is  $\rho = |\psi\rangle\langle\psi|$ , while in the very next it is a  $\Pi_i = |i\rangle\langle i|$ . Moreover, such a wild transition need depend upon no details of  $|\psi\rangle$  and  $|i\rangle$ ; in particular the two states may even

<sup>29</sup>David Mermin has also recently emphasized this point in Ref. [78].

<sup>30</sup>As an aside, it should be clear from the construction in Eq. (68) that there are many equally good representations of  $\rho_d$ . For a precise statement of the latitude of this freedom, see Ref. [79].

be almost orthogonal to each other. In density-operator language, there is no sense in which  $\Pi_i$  is contained in  $\rho$ : the two states are in distinct places of the operator space. That is,

$$\rho \neq \sum_i P(i)\Pi_i . \quad (69)$$

Contrast this with the description of information gathering that arises in Bayesian probability theory. There, an initial state of belief is captured by a probability distribution  $P(h)$  for some hypothesis  $H$ . The way gathering a piece of data  $d$  is taken into account in assigning one's new state of belief is through Bayes' conditionalization rule. That is to say, one expands  $P(h)$  in terms of the relevant joint probability distribution and picks off the appropriate term:

$$\begin{aligned} P(h) &= \sum_d P(h, d) \\ &= \sum_d P(d)P(h|d) \end{aligned} \quad (70)$$

↓

$$P(h) \xrightarrow{d} P(h|d) , \quad (71)$$

where  $P(h|d)$  satisfies the tautology

$$P(h|d) = \frac{P(h, d)}{P(d)} . \quad (72)$$

How gentle this looks in comparison to quantum collapse! When one gathers new information, one simply refines one's old beliefs in the most literal of senses. It is not as if the new state is incommensurable with the old. *It was always there*; it was just initially averaged in with various other potential beliefs.

Why does quantum collapse not look more like Bayes' rule? Is quantum collapse really a more violent kind of change, or might it be an artifact of a problematic representation? By this stage, it should come as no surprise to the reader that dropping the ancilla from our image of generalized measurements will be the first step to progress. Taking the transition from  $\rho$  to  $\rho_d$  in Eqs. (63) and (64) as the basic statement of what quantum measurement *is* is a good starting point.

To accentuate a similarity between Eq. (63) and Bayes' rule, let us first contemplate cases of it where the index  $i$  takes on a single value. Then, we can conveniently drop that index and write

$$\rho_d = \frac{1}{P(d)} A_d \rho A_d^\dagger , \quad (73)$$

where

$$E_d = A_d^\dagger A_d . \quad (74)$$

In a loose way, one can say that measurements of this sort are the most efficient they can be for a given POVM  $\{E_d\}$ : For, a measurement interaction with an explicit  $i$ -dependence may be viewed as "more truly" a measurement of a finer-grained POVM that just happens to throw away some of the information it gained. Let us make this point more precise.

Notice that Bayes' rule has the property that one's uncertainty about a hypothesis can be expected to decrease upon the acquisition of data. This can be made rigorous, for instance, by gauging uncertainty with the Shannon entropy function [80],

$$S(H) = - \sum_h P(h) \log P(h) . \quad (75)$$

This number is bounded between 0 and the logarithm of the number of hypotheses in  $H$ , and there are several reasons to think of it as a good measure of uncertainty. Perhaps the most important of these is that it quantifies the number of binary-valued questions one expects to ask (per instance of  $H$ ) if one's only means to ascertain the outcome is from a colleague who knows the result [81]. Under this quantification, the lower the Shannon entropy, the more predictable a measurement's outcomes.

Because the function  $f(x) = -x \log x$  is concave on the interval  $[0, 1]$ , it follows that,

$$\begin{aligned} S(H) &= -\sum_h \left( \sum_d P(d)P(h|d) \right) \log \left( \sum_d P(d)P(h|d) \right) \\ &\geq -\sum_d P(d) \sum_h P(h|d) \log P(h|d) . \\ &= \sum_d P(d)S(H|d) \end{aligned} \tag{76}$$

Indeed we hope to find a similar statement for how the result of efficient quantum measurements decrease uncertainty or unpredictability. But, what can be meant by a decrease of uncertainty through quantum measurement? I have argued strenuously that the information gain in a measurement cannot be information about a preexisting reality. The way out of the impasse is simple: The uncertainty that decreases in quantum measurement is the uncertainty one expects for the results of other potential measurements.

There are at least two ways of quantifying this that are worthy of note. The first has to do with the von Neumann entropy of a density operator  $\rho$ :

$$S(\rho) = -\text{tr} \rho \log \rho = -\sum_{k=1}^D \lambda_k \log \lambda_k , \tag{77}$$

where the  $\lambda_k$  signify the eigenvalues of  $\rho$ . (We use the convention that  $\lambda \log \lambda = 0$  whenever  $\lambda = 0$  so that  $S(\rho)$  is always well defined.)

The intuitive meaning of the von Neumann entropy can be found by first thinking about the Shannon entropy. Consider any von Neumann measurement  $\mathcal{P}$  consisting of  $D$  one-dimensional orthogonal projectors  $\Pi_i$ . The Shannon entropy for the outcomes of this measurement is given by

$$H(\mathcal{P}) = -\sum_{i=1}^D (\text{tr} \rho \Pi_i) \log (\text{tr} \rho \Pi_i) . \tag{78}$$

A natural question to ask is: With respect to a given density operator  $\rho$ , which measurement  $\mathcal{P}$  will give the most predictability over its outcomes? As it turns out, the answer is any  $\mathcal{P}$  that forms a set of eigenprojectors for  $\rho$  [82]. When this obtains, the Shannon entropy of the measurement outcomes reduces to simply the von Neumann entropy of the density operator. The von Neumann entropy, then, signifies the amount of unpredictability one achieves by way of a standard measurement in a best case scenario. Indeed, true to one's intuition, one has the most predictability by this account when  $\rho$  is a pure state—for then  $S(\rho) = 0$ . Alternatively, one has the least knowledge when  $\rho$  is proportional to the identity operator—for then any measurement  $\mathcal{P}$  will have outcomes that are all equally likely.

The best case scenario for predictability, however, is a limited case, and not very indicative of the density operator as a whole. Since the density operator contains, in principle, all that can be said about every possible measurement, it seems a shame to throw away the vast part of that information in our considerations.

This leads to a second method for quantifying uncertainty in the quantum setting. For this, we again rely on the Shannon information as our basic notion of unpredictability. The difference is we evaluate it with respect to a “typical” measurement rather than the best possible one. But typical with respect to what? The notion of typical is only defined with respect to a given *measure* on the set of measurements.

Regardless, there is a fairly canonical answer. There is a unique measure  $d\Omega_{\Pi}$  on the space of one-dimensional projectors that is invariant with respect to all unitary operations. That in turn induces a canonical measure  $d\Omega_{\mathcal{P}}$  on the space of von Neumann measurements  $\mathcal{P}$  [83]. Using this measure leads to the following quantity

$$\begin{aligned}\bar{S}(\rho) &= \int H(\Pi) d\Omega_{\mathcal{P}} \\ &= -D \int (\text{tr}\rho\Pi) \log(\text{tr}\rho\Pi) d\Omega_{\Pi} ,\end{aligned}\tag{79}$$

which is intimately connected to the so-called quantum “subentropy” of Ref. [84]. This mean entropy can be evaluated explicitly in terms of the eigenvalues of  $\rho$  and takes on the expression

$$\bar{S}(\rho) = \frac{1}{\ln 2} \left( \frac{1}{2} + \frac{1}{3} + \cdots + \frac{1}{D} \right) + Q(\rho)\tag{80}$$

where the subentropy  $Q(\rho)$  is defined by

$$Q(\rho) = - \sum_{k=1}^D \left( \prod_{i \neq k} \frac{\lambda_k}{\lambda_k - \lambda_i} \right) \lambda_k \log \lambda_k .\tag{81}$$

In the case where  $\rho$  has degenerate eigenvalues,  $\lambda_l = \lambda_m$  for  $l \neq m$ , one need only reset them to  $\lambda_l + \epsilon$  and  $\lambda_m - \epsilon$  and consider the limit as  $\epsilon \rightarrow 0$ . The limit is convergent and hence  $Q(\rho)$  is finite for all  $\rho$ . With this, one can also see that for a pure state  $\rho$ ,  $Q(\rho)$  vanishes. Furthermore, since  $\bar{S}(\rho)$  is bounded above by  $\log D$ , we know that

$$0 \leq Q(\rho) \leq \log D - \frac{1}{\ln 2} \left( \frac{1}{2} + \cdots + \frac{1}{D} \right) \leq \frac{1 - \gamma}{\ln 2} ,\tag{82}$$

where  $\gamma$  is Euler’s constant. This means that for any  $\rho$ ,  $Q(\rho)$  never exceeds approximately 0.60995 bits.

The interpretation of this result is the following. Even when one has maximal information about a quantum system—i.e., one has a pure state for it—one can predict almost nothing about the outcome of a typical measurement [40]. In the limit of large  $d$ , the outcome entropy for a typical measurement is just a little over a half bit away from its maximal value. Having a mixed state for a system, reduces one’s predictability even further, but indeed not by that much: The small deviation is captured by the function in Eq. (81), which becomes a quantification of uncertainty in its own right.

The way to get at a quantum statement of Eq. (76) is to make use of the fact that  $S(\rho)$  and  $Q(\rho)$  are both concave in the variable  $\rho$ . [85] That is, for either function, we have

$$F(t\tilde{\rho}_0 + (1-t)\tilde{\rho}_1) \geq tF(\tilde{\rho}_0) + (1-t)F(\tilde{\rho}_1) ,\tag{83}$$

for any density operators  $\tilde{\rho}_0$  and  $\tilde{\rho}_1$  and any real number  $t \in [0, 1]$ . Therefore, one might hope that

$$F(\rho) \geq \sum_d P(d)F(\rho_d) .\tag{84}$$



Such a result however—if it is true—cannot arise in the trivial fashion it did for the classical case of Eq. (76). This is because generally (as already emphasized),

$$\rho \neq \sum_d P(d)\rho_d \quad (85)$$

for  $\rho_d$  defined as in Eq. (73). One therefore must be more roundabout if a proof is going to happen. The key is in noticing that

$$\begin{aligned} \rho &= \rho^{1/2} I \rho^{1/2} \\ &= \sum_d \rho^{1/2} E_d \rho^{1/2} \\ &= \sum_d P(d) \tilde{\rho}_d \end{aligned} \quad (86)$$

where

$$\tilde{\rho}_d = \frac{1}{P(d)} \rho^{1/2} E_d \rho^{1/2} = \frac{1}{P(d)} \rho^{1/2} A_d^\dagger A_d \rho^{1/2} . \quad (87)$$

What is special about this decomposition of  $\rho$  is that for each  $d$ ,  $\rho_d$  and  $\tilde{\rho}_d$  have the same eigenvalues. This follows since  $X^\dagger X$  and  $XX^\dagger$  have the same eigenvalues, for any operator  $X$ . In the present case, setting  $X = A_d \rho^{1/2}$  does the trick. Using the fact that both  $S(\rho)$  and  $Q(\rho)$  depend only upon the eigenvalues of  $\rho$  we obtain:

$$S(\rho) \geq \sum_d P(d) S(\rho_d) \quad (88)$$

$$Q(\rho) \geq \sum_d P(d) Q(\rho_d) , \quad (89)$$

as we had been hoping for. Thus, in performing an efficient quantum measurement of a POVM  $\{E_d\}$ , an observer can expect to be left with less uncertainty than he started with.<sup>31</sup>

In this sense, quantum “collapse” does indeed have some of the flavor of Bayes’ rule. But we can expect more, and the derivation above hints at just the right ingredient:  $\rho_d$  and  $\tilde{\rho}_d$  have the same eigenvalues! To see the impact of this, let us once again explore the content of Eqs. (73) and (74). A common way to describe their meaning is to use the operator polar-decomposition theorem [87] to rewrite Eq. (73) in the form

$$\rho_d = \frac{1}{P(d)} U_d E_d^{1/2} \rho E_d^{1/2} U_d^\dagger , \quad (90)$$

where  $U_d$  is a unitary operator. Since—subject only to the constraint of efficiency—the operators  $A_d$  are not determined any further than Eq. (74),  $U_d$  can be *any* unitary operator whatsoever. Thus, a customary way of thinking of the state-change process is to break it up into two conceptual pieces. First there is a “raw collapse”:

$$\rho \longrightarrow \sigma_d = \frac{1}{P(d)} E_d^{1/2} \rho E_d^{1/2} . \quad (91)$$

Then, subject to the details of the measurement interaction and the particular outcome  $d$ , one imagines the measuring device enforcing a further kind of “back-action” or “feedback” on the measured system [88]:

$$\sigma_d \longrightarrow \rho_d = U_d \sigma_d U_d^\dagger . \quad (92)$$

---

<sup>31</sup>By differing methods, a strengthening of this result in terms of a majorization property can be found in Refs. [85] and [86].

But this breakdown of the transition is a purely conceptual game.

Since the  $U_d$  are arbitrary to begin with, we might as well break down the state-change process into the following (nonstandard) conceptual components. First one imagines an observer refining his initial state of belief and simply plucking out a term corresponding to the “data” collected:

$$\rho = \sum_d P(d) \tilde{\rho}_d \quad (93)$$

↓

$$\rho \xrightarrow{d} \tilde{\rho}_d . \quad (94)$$

Finally, there may be a further “mental readjustment” of the observer’s beliefs, which takes into account details both of the measurement interaction and the observer’s initial quantum state. This is enacted via some (formal) unitary operation  $V_d$ :

$$\tilde{\rho}_d \longrightarrow \rho_d = V_d \tilde{\rho}_d V_d^\dagger . \quad (95)$$

Putting the two processes together, one has the same result as the usual picture.

The resemblance between the process in Eq. (94) and the classical Bayes’ rule of Eq. (71) is uncanny.<sup>32</sup> By this way of viewing things, quantum collapse is indeed not such a violent state of affairs after all. Quantum measurement is nothing more, and nothing less, than a refinement and a readjustment of one’s initial state of belief. More general state changes of the form Eq. (63) come about similarly, but with a further step of coarse-graining (i.e., throwing away information that was in principle accessible).

Let us look at two limiting cases of efficient measurements. In the first, we imagine an observer whose initial belief structure  $\rho = |\psi\rangle\langle\psi|$  is a maximally tight state of belief. By this account, no measurement whatsoever can *refine* it. This follows because, no matter what  $\{E_d\}$  is,

$$\rho^{1/2} E_d \rho^{1/2} = P(d) |\psi\rangle\langle\psi| . \quad (96)$$

The only state change that can come about from a measurement must be purely of the mental-readjustment sort: We learn nothing new; we just change what we can predict as a consequence of the side effects of our experimental intervention. That is to say, there is a sense in which the measurement is solely disturbance. In particular, when the POVM is an orthogonal set of projectors  $\{\Pi_i = |i\rangle\langle i|\}$  and the state-change mechanism is the von Neumann collapse postulate, this simply corresponds to a readjustment according to unitary operators  $U_i$  whose action in the subspace spanned by  $|\psi\rangle$  is

$$|i\rangle\langle\psi| . \quad (97)$$

At the opposite end of things, we can contemplate measurements that have no possibility at all of causing a physical disturbance to the system being measured. This could come about, for instance, by interacting with one side of an entangled pair of systems and using the consequence of that intervention to update one’s beliefs about the other side. In such a case, one can show that the state change is purely of the refinement variety (with no further mental readjustment).<sup>33</sup> For instance, consider a pure state  $|\psi^{AB}\rangle$  whose Schmidt decomposition takes the form

$$|\psi^{AB}\rangle = \sum_i \sqrt{\lambda_i} |a_i\rangle |b_i\rangle . \quad (98)$$

---

<sup>32</sup>Other similarities between quantum collapse and Bayesian conditionalization have been discussed in Refs. [89, 90, 91].

<sup>33</sup>This should be contrasted with the usual picture of a “minimally disturbing” measurement of some POVM. In our case, a minimal disturbance version of a POVM  $\{E_d\}$  corresponds to taking  $V_d = I$  for all  $d$  in Eq. (95). In the usual presentation—see Refs. [85] and [88]—it corresponds to taking  $U_d = I$  for all  $d$  in Eq. (92) instead. For

An efficient measurement on the  $A$  side of this leads to a state update of the form

$$|\psi^{AB}\rangle\langle\psi^{AB}| \longrightarrow (A_d \otimes I)|\psi^{AB}\rangle\langle\psi^{AB}|(A_d^\dagger \otimes I). \quad (99)$$

Tracing out the  $A$  side, then gives

$$\begin{aligned} \text{tr}_A \left( A_d \otimes I |\psi^{AB}\rangle\langle\psi^{AB}| A_d^\dagger \otimes I \right) &= \sum_{ijk} \sqrt{\lambda_j} \sqrt{\lambda_k} \langle a_i | A_d \otimes I | a_j \rangle | b_j \rangle \langle a_k | \langle b_k | A_d^\dagger \otimes I | a_i \rangle \\ &= \sum_{ijk} \sqrt{\lambda_j} \sqrt{\lambda_k} \langle a_k | A_d^\dagger | a_i \rangle \langle a_i | A_d | a_j \rangle | b_j \rangle \langle b_k | \\ &= \sum_{jk} \sqrt{\lambda_j} \sqrt{\lambda_k} \langle a_k | A_d^\dagger A_d | a_j \rangle | b_j \rangle \langle b_k | \\ &= \sum_{jk} \sqrt{\lambda_j} \sqrt{\lambda_k} \langle b_k | U A_d^\dagger A_d U^\dagger | b_j \rangle | b_j \rangle \langle b_k | \\ &= \sum_{jk} \sqrt{\lambda_j} \sqrt{\lambda_k} \langle b_j | \left( U A_d^\dagger A_d U^\dagger \right)^\top | b_k \rangle | b_j \rangle \langle b_k | \\ &= \rho^{1/2} \left( U A_d^\dagger A_d U^\dagger \right)^\top \rho^{1/2} \end{aligned} \quad (100)$$

where  $\rho$  is the initial quantum state on the  $B$  side,  $U$  is the unitary operator connecting the  $|a_i\rangle$  basis to the  $|b_i\rangle$  basis, and  $^\top$  represents taking a transpose with respect to the  $|b_i\rangle$  basis. Since the operators

$$F_d = \left( U A_d^\dagger A_d U^\dagger \right)^\top \quad (101)$$

go together to form a POVM, we indeed have the claimed result.

In summary, the lesson here is that it turns out to be rather easy to think of quantum collapse as a noncommutative variant of Bayes' rule. In fact it is just in this that one starts to get a feel for a further reason for Gleason's noncontextuality assumption. In the setting of classical Bayesian conditionalization we have just that: The probability of the transition  $P(h) \longrightarrow P(h|d)$  is governed solely by the local probability  $P(d)$ . The transition does not care about how we have partitioned the rest of the potential transitions. That is, it does not care whether  $d$  is embedded in a two outcome set  $\{d, \neg d\}$  or whether it is embedded in a three outcome set,  $\{d, e, \neg(d \vee e)\}$ , etc. Similarly with the quantum case. The probability for a transition from  $\rho$  to  $\rho_0$  cares not whether our refinement is of the form

$$\rho = P(0)\rho_0 + \sum_{d=1}^{17} P(d)\rho_d \quad \text{or of the form} \quad \rho = P(0)\rho_0 + P(18)\rho_{18}, \quad (102)$$

as long as

$$P(18)\rho_{18} = \sum_{d=1}^{17} P(d)\rho_d \quad (103)$$

---

instance, Howard Wiseman writes in Ref. [88]:

The action of  $[E_d^{1/2}]$  produces the minimum change in the system, required by Heisenberg's relation, to be consistent with a measurement giving the information about the state specified by the probabilities [Eq. (8)]. The action of  $[U_d]$  represents additional back-action, an unnecessary perturbation of the system. ... A back-action evading measurement is reasonably defined by the requirement that, for all  $[d]$ ,  $[U_d]$  equals unity (up to a phase factor that can be ignored without loss of generality).

This of course means that, from the present point of view, there is no such thing as a state-independent notion of minimally disturbing measurement. Given an initial state  $\rho$  and a POVM  $\{E_d\}$ , the minimally disturbing measurement interaction is the one that produces pure Bayesian updating with no further (purely quantum) readjustment.

What could be a simpler generalization of Bayes’ rule?

Indeed, leaning on that, we can restate the discussion of the “measurement problem” at the beginning of Section 4 in slightly more technical terms. Go back to the classical setting of Eqs. (70) and (72) where an agent has a probability distribution  $P(h, d)$  over two sets of hypotheses. Marginalizing over the possibilities for  $d$ , one obtains the agent’s initial belief  $P(h)$  about the hypothesis  $h$ . If he gathers an explicit piece of data  $d$ , he should use Bayes’ rule to update his probability about  $h$  to  $P(h|d)$ .

The question is this: Is the transition

$$P(h) \longrightarrow P(h|d) \tag{104}$$

a mystery we should contend with? If someone asked for a *physical description* of this transition, would we be able to give an explanation? After all, one value for  $h$  is true and always remains true: there is no transition in it. One value for  $d$  is true and always remains true: there is no transition in it. The only discontinuous transition is in the *belief*  $P(h)$ , and that presumably is a property of the believer’s brain. To put the issue into terms that start to sound like the quantum measurement problem, let us ask: Should we not have a detailed theory of how the brain works before we can trust in the validity of Bayes’ rule?<sup>34</sup>

The answer is, “Of course not!” Bayes’ rule—and beyond it all of probability theory—is a tool that stands above the details of physics. George Boole called probability theory a *law of thought* [94]. Its calculus specifies the optimal way an agent should reason and make decisions when faced with incomplete information. In this way, probability theory is a generalization of Aristotelian logic<sup>35</sup>—a tool of thought few would accept as being anchored to the details of the physical world.<sup>36</sup> As far as Bayesian probability theory is concerned, a “classical measurement” is simply any *I-know-not-what* that induces an application of Bayes’ rule. It is not the task of probability theory (nor is it solvable within probability theory) to explain how the transition Bayes’ rule signifies comes about within the mind of the agent.

---

<sup>34</sup>This point was recently stated much more eloquently by Rocco Duvnhage in his paper Ref. [92]:

In classical mechanics a measurement is nothing strange. It is merely an event where the observer obtains information about some physical system. A measurement therefore changes the observer’s information regarding the system. One can then ask: What does the change in the observer’s information mean? What causes it? And so on. These questions correspond to the questions above, but now they seem tautological rather than mysterious, since our intuitive idea of information tells us that the change in the observer’s information simply means that he has received new information, and that the change is caused by the reception of the new information. We will see that the quantum case is no different . . .

Let’s say an observer has information regarding the state of a classical system, but not necessarily complete information (this is the typical case, since precise measurements are not possible in practice). Now the observer performs a measurement on the system to obtain new information . . . The observer’s information after this measurement then differs from his information before the measurement. In other words, a measurement “disturbs” the observer’s information. . . .

The Heisenberg cut. This refers to an imaginary dividing line between the observer and the system being observed . . . It can be seen as the place where information crosses from the system to the observer, but it leads to the question of where exactly it should be; where does the observer begin? In practice it’s not really a problem: It doesn’t matter where the cut is. It is merely a philosophical question which is already present in classical mechanics, since in the classical case information also passes from the system to the observer and one could again ask where the observer begins. The Heisenberg cut is therefore no more problematic in quantum mechanics than in classical mechanics.

<sup>35</sup>In addition to Ref. [76], many further materials concerning this point of view can be downloaded from the *Probability Theory As Extended Logic* web site maintained by G. L. Bretthorst, <http://bayes.wustl.edu/>.

<sup>36</sup>We have, after all, used simple Aristotelian logic in making deductions from *all* our physical theories to date: from Aristotle’s physics to quantum mechanics to general relativity and even string theory.

The formal similarities between Bayes’ rule and quantum collapse may be telling us how to finally cut the Gordian knot of the measurement problem. Namely, it may be telling us that it is simply not a problem at all! Indeed, drawing on the analogies between the two theories, one is left with a spark of insight: perhaps the better part of quantum mechanics is simply “law of thought” [56]. Perhaps the structure of the theory denotes the optimal way to reason and make decisions in light of *some* fundamental situation—a fundamental situation waiting to be ferreted out in a more satisfactory fashion.

This much we know: That fundamental situation—whatever it is—must be an ingredient Bayesian probability theory does not have. As already emphasized, there must be something to drive a wedge between the two theories. Probability theory alone is too general a structure. Narrowing the structure will require input from the world around us.

## 6.1 Accepting Quantum Mechanics

Looking at the issue from this perspective, let us ask: What does it mean to accept quantum mechanics? Does it mean accepting (in essence) the existence of an “expert” whose probabilities we should strive to possess whenever we strive to be maximally rational? [93] The key to answering this question comes from combining the previous discussion of Bayes’ rule with the considerations of the standard quantum-measurement device of Section 4.2. For, contemplating this will allow us to go even further than calling quantum collapse a noncommutative *variant* of Bayes’ rule.

Consider the description of quantum collapse in Eqs. (93) through (95) in terms of one’s subjective judgments for the outcomes of a standard quantum measurement  $\{E_h\}$ . Using the notation there, one starts with an initial judgment

$$P(h) = \text{tr}(\rho E_h) \tag{105}$$

and, after a measurement of some other observable  $\{E_d\}$ , ends up with a final judgment

$$P_d(h) = \text{tr}(\rho_d E_h) = \text{tr}(\tilde{\rho}_d V_d^\dagger E_h V_d) = \text{tr}(\tilde{\rho}_d F_h^d), \tag{106}$$

where

$$F_h^d = V_d^\dagger E_h V_d. \tag{107}$$

Note that, in general,  $\{E_h\}$  and  $\{E_d\}$  refer to two entirely different POVMs; the range of their indices  $h$  and  $d$  need not even be the same. Also, since  $\{E_h\}$  is a minimal informationally complete POVM,  $\{F_h^d\}$  will itself be informationally complete for each value of  $d$ .

Thus, *modulo a final unitary readjustment or redefinition of the standard quantum measurement* based on the data gathered, one has precisely Bayes’ rule in this transition. This follows since

$$\rho = \sum_d P(d) \tilde{\rho}_d \tag{108}$$

implies

$$P(h) = \sum_d P(d) P(h|d), \tag{109}$$

where

$$P(h|d) = \text{tr}(\tilde{\rho}_d E_h). \tag{110}$$

Another way of looking at this transition is from the “active” point of view, i.e., that the axes of the probability simplex are held fixed, while the state is transformed from  $P(h|d)$  to  $P_d(h)$ . That is, writing

$$F_h^d = \sum_{h'=1}^{D^2} \Gamma_{hh'}^d E_{h'} \tag{111}$$

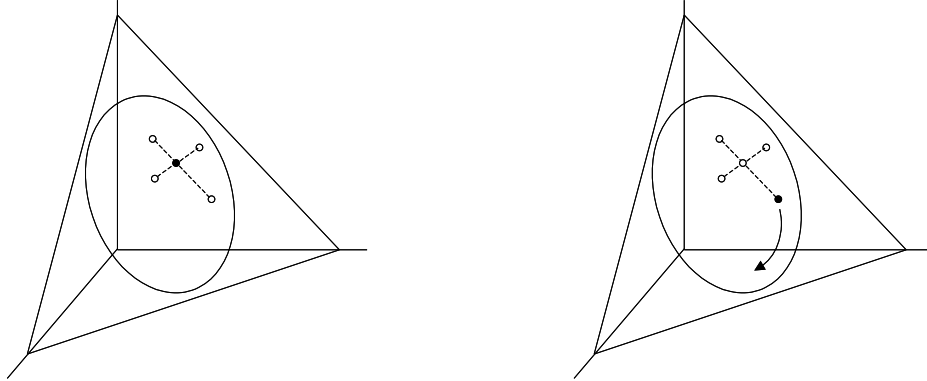

Figure 2: A quantum measurement is any “I-know-not-what” that generates an application of Bayes’ rule to one’s beliefs for the outcomes of a standard quantum measurement—that is, a decomposition of the initial state into a convex combination of other states and then a final “choice” (decided by the world, not the observer) within that set. Taking into account the idea that quantum measurements are “invasive” or “disturbing” alters the classical Bayesian picture only in introducing a further outcome-dependent readjustment: One can either think of it passively as a readjustment of the standard quantum measurement device, or actively (as depicted here) as a further adjustment to the posterior state.

where  $\Gamma_{hh'}^d$  are some real-valued coefficients and  $\{E_{h'}\}$  refers to a relabeling of the original standard quantum measurement, we get

$$P_d(h) = \sum_{h'=1}^{D^2} \Gamma_{hh'}^d P(h'|d). \quad (112)$$

This gives an enticingly simple description of what quantum measurement *is* in Bayesian terms. Modulo the final readjustment, a quantum measurement is *any application of Bayes’ rule whatsoever* on the initial state  $P(h)$ . By any application of Bayes’ rule, I mean in particular any convex decomposition of  $P(h)$  into some refinements  $P(h|d)$  that also live in  $\mathcal{P}_{\text{SQM}}$ .<sup>37</sup> Aside from the final readjustment, a quantum measurement is just like a classical measurement: It is *any I-know-not-what* that pushes an agent to an application of Bayes’ rule.<sup>38</sup>

Accepting the formal structure of quantum mechanics is—in large part—simply accepting that it would not be in one’s best interest to hold a  $P(h)$  that falls outside the convex set  $\mathcal{P}_{\text{SQM}}$ . Moreover, up to the final conditionalization rule signified by a unitary operator  $V_d$ , a measurement is simply

<sup>37</sup>Note a distinction between this way of posing Bayes’ rule and the usual way. In stating it, I give no status to a joint probability distribution  $P(h, d)$ . If one insists on calling the product  $P(d)P(h|d)$  a joint distribution  $P(h, d)$ , one can do so of course, but it is only a mathematical artifice without intrinsic meaning. In particular, one should not get a feeling from  $P(h, d)$ ’s mathematical existence that the random variables  $h$  and  $d$  simultaneously coexist. As always,  $h$  and  $d$  stand only for the consequences of experimental interventions into nature; without the intervention, there is no  $h$  and no  $d$ .

<sup>38</sup>Of course, I fear the wrath my choice of words “any I-know-not-what” will bring down upon me. For it will be claimed—I can see it now, rather violently—that I do not understand the first thing of what the “problem” of quantum measurement is: It is to supply a mechanism for understanding how collapse comes about, not to dismiss it. But my language is honest language and meant explicitly to leave nothing hidden. The point here, as already emphasized in the classical case, is that it is not the task—and cannot be the task—of a theory that makes intrinsic use of probability to justify how an agent has gotten hold of a piece of information that causes him to change his beliefs. A belief is a property of one’s head, not of the object of one’s interest.

anything that can cause an application of Bayes’ rule within  $\mathcal{P}_{\text{SQM}}$ .

But if there is nothing more than arbitrary applications of Bayes’ rule to ground the concept of quantum measurement, would not the solidity of quantum theory melt away? What else can determine when “this” rather than “that” measurement is performed? Surely that much has to be objective about the theory?

## 7 What Else Is Information?

That’s territory I’m not yet ready to follow you into.  
Good luck!

— *N. David Mermin*, 2002

Suppose one wants to hold adamantly to the idea that the quantum state is purely subjective. That is, that there is no right and true quantum state for a system—the quantum state is “numerically additional” to the quantum system. It walks through the door when the agent who is interested in the system walks through the door. Can one consistently uphold this point of view at the same time as supposing that *which* POVM  $\{E_d\}$  and *which* state-change rule  $\rho \rightarrow \rho_d = A_d \rho A_d^\dagger$  a measurement device performs are objective features of the device? The answer is no, and it is not difficult to see why.

Take as an example, a device that supposedly performs a standard von Neumann measurement  $\{\Pi_d\}$ , the measurement of which is accompanied by the standard collapse postulate. Then when a click  $d$  is found, the posterior quantum state will be  $\rho_d = \Pi_d$  regardless of the initial state  $\rho$ . If this state-change rule is an objective feature of the device or its interaction with the system—i.e., it has nothing to do with the observer’s subjective judgment—then the final state  $\rho_d$  too must be an objective feature of the quantum system. The argument is that simple. Furthermore, it clearly generalizes to all state change rules for which the  $A_d$  are rank-one operators without adding any further complications.

Also though, since the operators  $E_d$  control the maximal support<sup>39</sup> of the final state  $\rho_d$  through  $A_d = U_d E_d^{1/2}$ , it must be that even the  $E_d$  themselves are subjective judgments. For otherwise, one would have a statement like, “Only states with support within a subspace  $\mathcal{S}_d$  are *correct*. All other states are simply *wrong*.”<sup>40</sup>

Thinking now of uninterrupted quantum time evolution as the special case of what happens to a state after the single-element POVM  $\{I\}$  is performed, one is forced to the same conclusion even in that case. The time evolution super-operator for a quantum system—most generally a completely positive trace-preserving linear map on the space of operators for  $\mathcal{H}_D$  [50]—is a subjective judgment on exactly the same par as the subjectivity of the quantum state.

Here is another way of seeing the same thing. Recall what I viewed to be the most powerful argument for the quantum state’s subjectivity—the Einsteinian argument of Section 3. Since we can toggle the quantum state from a distance, it must not be something sitting over there, but rather something sitting over here: It can only be our information about the far-away system. Let us now apply a variation of this argument to time evolutions.

Consider a simple quantum circuit on a bipartite quantum system that performs a controlled unitary operation  $U_i$  on the target bit. (For simplicity, let us say the bipartite system consists of two qubits.) Which unitary operation the circuit applies depends upon which state  $|i\rangle$ ,  $i = 0, 1$ , of

<sup>39</sup>The support of an operator is the subspace spanned by its eigenvectors with nonzero eigenvalues.

<sup>40</sup>Such a statement, in fact, is not so dissimilar to the one found in Ref. [95]. For several rebuttals of that idea, see Ref. [2] and [96].

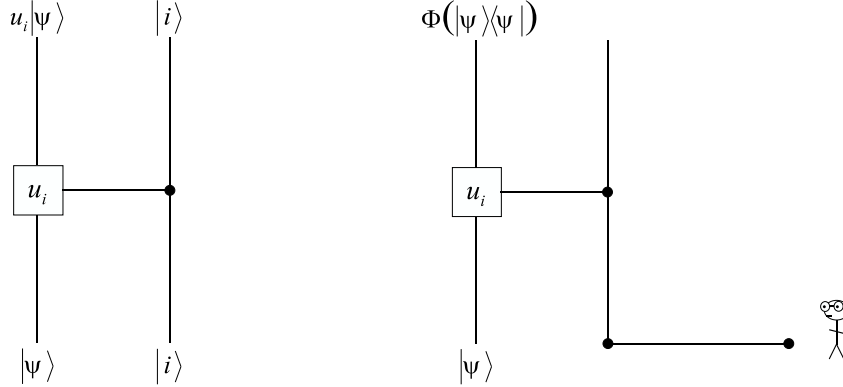

Figure 3: One can use a slight modification of Einstein’s argument for the subjectivity of the quantum state to draw the same conclusion for quantum time evolutions. By performing measurements on a far away system, one will ascribe one or another completely positive map to the evolution of the left-most qubit. Therefore, accepting physical locality, the time evolution map so ascribed cannot be a property intrinsic to the system.

two orthogonal states impinges upon the control bit. Thus, for an arbitrary state  $|\psi\rangle$  on the target, one finds

$$|i\rangle|\psi\rangle \longrightarrow |i\rangle(U_i|\psi\rangle) \quad (113)$$

for the overall evolution. Consequently the evolution of the target system alone is given by

$$|\psi\rangle \longrightarrow U_i|\psi\rangle \quad (114)$$

On the other hand, suppose the control bit is prepared in a superposition state  $|\phi\rangle = \alpha|0\rangle + \beta|1\rangle$ . Then the evolution for the target bit will be given by a completely positive map  $\Phi_\phi$ . That is,

$$|\psi\rangle \longrightarrow \Phi_\phi(|\psi\rangle\langle\psi|) = |\alpha|^2 U_0|\psi\rangle\langle\psi|U_0^\dagger + |\beta|^2 U_1|\psi\rangle\langle\psi|U_1^\dagger. \quad (115)$$

Now, to the point. Suppose rather than feeding a single qubit into the control bit, we feed half of an entangled pair, where the other qubit is physically far removed from the circuit. If an observer with this description of the whole set-up happens to make a measurement on the far-away qubit, then he will be able to induce any of a number of completely positive maps  $\Phi_\phi$  on the control bit. These will depend upon which measurement he performs and which outcome he gets. The point is the same as before: Invoking physical locality, one obtains that the time evolution mapping on the single qubit cannot be an objective state of affairs localized at that qubit. The time evolution, like the state, is subjective information.<sup>4142</sup>

<sup>41</sup>Of course, there are sideways moves one can use to try to get around this conclusion. For instance, one could argue that, “The time evolution operator  $\Phi$  on the control qubit is only an ‘effective’ evolution for it. The ‘true’ evolution for the system is the unitary evolution specified by the complete quantum circuit.”[97] In my opinion, however, moves like this are just prostrations to the Everettic temple. One could dismiss the original Einsteinian argument in the same way: “The observer toggles nothing with his localized measurement; the ‘true’ quantum state is the universal quantum state. All that is going on in a quantum measurement is the revelation of a relative state—i.e., the ‘effective’ quantum state.” How can one argue with this, other than to say it is not the most productive stance and that the evidence shows that since 1957 it has not been able to quell the foundations debate. See Footnote 12.

<sup>42</sup>A strengthening of this argument may also be found in the same way as in Section 3: Namely, by considering the teleportation of quantum dynamics. I will for the moment, however, leave that as an exercise for the reader. See the many references in Ref. [98] for appropriate background.



It has long been known that the trace preserving completely positive linear maps  $\Phi$  over a  $D$ -dimensional vector space can be placed in a one-to-one correspondence with density operators on a  $D^2$ -dimensional space via the relation [79, 99, 100]

$$\Upsilon = I \otimes \Phi(|\psi_{\text{ME}}\rangle\langle\psi_{\text{ME}}|) \quad (116)$$

where  $|\psi_{\text{ME}}\rangle$  signifies a maximally entangled state on  $\mathcal{H}_{\text{D}} \otimes \mathcal{H}_{\text{D}}$ ,

$$|\psi_{\text{ME}}\rangle = \frac{1}{\sqrt{D}} \sum_{i=1}^D |i\rangle|i\rangle. \quad (117)$$

This is usually treated as a convenient representation theorem only, but maybe it is no mathematical accident. Perhaps there is a deep physical reason for it: The time evolution one ascribes to a quantum system IS a density operator! It is a quantum state of belief no more and no less than the initial quantum state one assigns to that same system.

How to think about this? Let us go back to the issue that closed the last section. How can one possibly identify the meaning of a measurement in the Bayesian view, where a measurement ascription is itself subjective—i.e., a measurement finds a mathematical expression only in the subjective refinement of some agent’s beliefs? Here is the difficulty. When one agent contemplates viewing a piece of data  $d$ , he might be willing to use the data to refine his beliefs according to

$$P(h) = \sum_d P(d)P(h|d). \quad (118)$$

However there is nothing to stop another agent from thinking the same data warrants him to refine his beliefs according to

$$Q(h) = \sum_d Q(d)Q(h|d). \quad (119)$$

A priori, there need be no relation between the  $P$ ’s and the  $Q$ ’s.

A relation only comes when one seeks a criterion for when the two agents will say that they believe they are drawing the same meaning from the data they obtain. That identification is a purely voluntary act; for there is no way for the agent to walk outside of his beliefs and see the world as it completely and totally is. The standard Bayesian solution to the problem is this: When both agents accept the same “statistical model” for their expectations of the data  $d$  given a hypothesis  $h$ , then they will agree to the identity of the measurements they are each (separately) considering. I.e., two agents will say they are performing the same measurement when and only when

$$P(d|h) = Q(d|h), \quad \forall h \text{ and } \forall d. \quad (120)$$

Putting this in a more evocative form, we can say that both agents agree to the meaning of a measurement when they adopt the same resolution of the identity

$$1 = \sum_d \frac{P(d)P(h|d)}{P(h)} = \sum_d \frac{Q(d)Q(h|d)}{Q(h)}. \quad (121)$$

with which to describe it.

With this, the relation to quantum measurement should be apparent. If we take it seriously that a measurement is anything that generates a refinement of one’s beliefs, then an agent specifies a measurement when he specifies a resolution of his initial density operator

$$\rho = \sum_d P(d) \tilde{\rho}_d. \quad (122)$$

But again, there is nothing to stop another agent from thinking the data warrants a refinement that is completely unrelated to the first:

$$\sigma = \sum_d Q(d) \tilde{\sigma}_d . \quad (123)$$

And that is where the issue ends if the agents have no further agreement.

Just as in the classical case, however, there is a solution for the identification problem. Using the canonical construction of Eq. (86), we can say that both agents agree to the meaning of a measurement when they adopt the same resolution of the identity,

$$I = \sum_d P(d) \rho^{-1/2} \tilde{\rho}_d \rho^{-1/2} = \sum_d Q(d) \sigma^{-1/2} \tilde{\sigma}_d \sigma^{-1/2} \quad (124)$$

with which to describe it.

Saying it in a more tautological way, two agents will be in agreement on the identity of a measurement when they assign it the same POVM  $\{E_d\}$ ,

$$E_d = P(d) \rho^{-1/2} \tilde{\rho}_d \rho^{-1/2} = Q(d) \sigma^{-1/2} \tilde{\sigma}_d \sigma^{-1/2} . \quad (125)$$

The importance of this move, however, is that it draws out the proper way to think about the operators  $E_d$  from the present perspective. They play part of the role of the “statistical model”  $P(d|h)$ . More generally, that role is fulfilled by the complete state change rule:

$$P(d|h) \quad \longleftrightarrow \quad \rho \rightarrow \rho_d \quad (126)$$

That is to say, drawing the correspondence in different terms,

$$P(d|h) \quad \longleftrightarrow \quad \Phi_d(\cdot) = U_d E_d^{1/2} \cdot E_d^{1/2} U_d^\dagger . \quad (127)$$

(Of course, more generally—for nonefficient measurements— $\Phi_d(\cdot)$  may consist of a convex sum of such terms.)

The completely positive map that gives a mathematical description to quantum time evolution is just such a map. Its role is that of the subjective statistical model  $P(d|h)$ , where  $d$  just happens to be drawn from a one-element set.

Thus, thinking back on entanglement, it seems the general structure of quantum time evolutions cannot be the wedge we are looking for either. What we see instead is that there is a secret waiting to be unlocked, and when it is unlocked, it will very likely tell us as much about quantum time evolutions as quantum states and quantum measurements.

## 8 Intermission

Let us take a deep breath. Up until now I have tried to trash about as much quantum mechanics as I could, and I know that takes a toll—it has taken one on me. Section 3 argued that quantum states—whatever they are—cannot be objective entities. Section 4 argued that there is nothing sacred about the quantum probability rule and that the best way to think of a quantum state is as a state of belief about what *would* happen if one were to ever approach a standard measurement device locked away in a vault in Paris. Section 5 argued that even our hallowed quantum entanglement is a secondary and subjective effect. Section 6 argued that all a measurement *is* is just an arbitrary application of Bayes’ rule—an arbitrary refinement of one’s beliefs—along with some account that measurements are invasive interventions into nature. Section 7 argued that even quantum time

evolutions are subjective judgments; they just so happen to be conditional judgments. . . . And, so it went.

Subjective. Subjective! Subjective!! It is a word that will not go away. But subjectivity is not something to be worshipped for its own sake. There are limits: The last thing we need is a bloodbath of deconstruction. At the end of the day, there had better be some term, some element in quantum theory that stands for the objective, or we might as well melt away and call this all a dream.

I turn now to a more constructive phase.

## 9 Unknown Quantum States?

My thesis, paradoxically, and a little provocatively, but nonetheless genuinely, is simply this:

QUANTUM STATES DO NOT EXIST.

The abandonment of superstitious beliefs about the existence of Phlogiston, the Cosmic Ether, Absolute Space and Time, . . ., or Fairies and Witches, was an essential step along the road to scientific thinking. The quantum state, too, if regarded as something endowed with some kind of objective existence, is no less a misleading conception, an illusory attempt to exteriorize or materialize our true probabilistic beliefs.

— *the true ghost of Bruno de Finetti*

The hint of a more fruitful direction can be found by trying to make sense of one of the most commonly used phrases in quantum information theory from a Bayesian perspective. It is the *unknown quantum state*. There is hardly a paper in quantum information that does not make use of it. Unknown quantum states are teleported [23], protected with quantum error correcting codes [101], and used to check for quantum eavesdropping [102]. The list of uses grows each day. But what can the term mean? In an information-based interpretation of quantum mechanics, it is an oxymoron: If quantum states, by their very definition, are states of subjective information and not states of nature, then the state is *known* by someone—at the very least, by the person who wrote it down.

Thus, if a phenomenon ostensibly invokes the concept of an unknown state in its formulation, that unknown state had better be shorthand for a more basic situation (even if that basic situation still awaits a complete analysis). This means that for any phenomenon using the idea of an unknown quantum state in its description, we should demand that either

1. The owner of the unknown state—a further decision-making agent or observer—be explicitly identified. (In this case, the unknown state is merely a stand-in for the unknown *state of belief* of an essential player who went unrecognized in the original formulation.) Or,
2. If there is clearly no further agent or observer on the scene, then a way must be found to reexpress the phenomenon with the term “unknown state” completely banished from its formulation. (In this case, the end-product of the effort will be a single quantum state used for describing the phenomenon—namely, the state that actually captures the describer’s overall set of beliefs throughout.)

This Section reports the work of Ref. [32] and [33], where such a project is carried out for the experimental practice of *quantum-state tomography* [31]. The usual description of tomography is

this. A device of some sort, say a nonlinear optical medium driven by a laser, repeatedly prepares many instances of a quantum system, say many temporally distinct modes of the electromagnetic field, in a fixed quantum state  $\rho$ , pure or mixed [103]. An experimentalist who wishes to characterize the operation of the device or to calibrate it for future use may be able to perform measurements on the systems it prepares even if he cannot get at the device itself. This can be useful if the experimenter has some prior knowledge of the device’s operation that can be translated into a probability distribution over states. Then learning about the state will also be learning about the device. Most importantly, though, this description of tomography assumes that the precise state  $\rho$  is unknown. The goal of the experimenter is to perform enough measurements, and enough kinds of measurements (on a large enough sample), to estimate the identity of  $\rho$ .

This is clearly an example where there is no further player on whom to pin the unknown state as a state of belief or judgment. Any attempt to find such a missing player would be entirely artificial: Where would the player be placed? On the inside of the device the tomographer is trying to characterize?<sup>43</sup> The only available course is the second strategy above—to banish the idea of the unknown state from the formulation of tomography.

To do this, we once again take our cue from Bayesian probability theory [75, 76, 77]. As emphasized previously, in Bayesian theory probabilities—just like quantum states—are not objective states of nature, but rather measures of belief, reflecting one’s operational commitments in various gambling scenarios. In light of this, it comes as no surprise that one of the most overarching Bayesian themes is to identify the conditions under which a set of decision-making agents can come to a common belief or probability assignment for a random variable even though their initial beliefs may differ [77]. Following that theme is the key to understanding the essence of quantum-state tomography.

Indeed, classical Bayesian theory encounters almost precisely the same problem as our unknown quantum state through the widespread use of the phrase “unknown probability” in its domain. This is an oxymoron every bit as egregious as unknown state.

The procedure analogous to quantum-state tomography in Bayesian theory is the estimation of an unknown probability from the results of repeated trials on “identically prepared systems.” The way to eliminate unknown probabilities from this situation was introduced by Bruno de Finetti in the early 1930s [104]. His method was simply to focus on the equivalence of the repeated trials—namely, that what is really important is that the systems are indistinguishable as far as probabilistic predictions are concerned. Because of this, any probability assignment  $p(x_1, x_2, \dots, x_N)$  for multiple trials should be symmetric under permutation of the systems. As innocent as this conceptual shift may sound, de Finetti was able to use it to powerful effect. For, with his *representation theorem*, he showed that any multi-trial probability assignment that is permutation-symmetric for an arbitrarily large number of trials—de Finetti called such multi-trial probabilities *exchangeable*—is equivalent to a probability for the “unknown probabilities.”

Let us outline this in a little more detail. In an objectivist description of  $N$  “identically prepared systems,” the individual trials are described by discrete random variables  $x_n \in \{1, 2, \dots, k\}$ ,  $n = 1, \dots, N$ , and the probability in the multi-trial hypothesis space is given by an independent

---

<sup>43</sup>Placing the player here would be about as respectable as George Berkeley’s famous patch to his philosophical system of idealism. The difficulty is captured engagingly by a limerick of Ronald Knox and its anonymous reply:

There was a young man who said, “God : Must think it exceedingly odd : If he finds that this tree : Continues to be : When there’s no one about in the Quad.”  
 REPLY: “Dear Sir: Your astonishment’s odd. : I am always about in the Quad. : And that’s why the tree : Will continue to be, : Since observed by Yours faithfully, God.”

identically distributed distribution

$$p(x_1, x_2, \dots, x_N) = p_{x_1} p_{x_2} \cdots p_{x_N} = p_1^{n_1} p_2^{n_2} \cdots p_k^{n_k} . \quad (128)$$

The numbers  $p_j$  describe the objective, “true” probability that the result of a single experiment will be  $j$  ( $j = 1, \dots, k$ ). The variable  $n_j$ , on the other hand, describes the number of times outcome  $j$  is listed in the vector  $(x_1, x_2, \dots, x_N)$ . But this description—for the objectivist—only describes the situation from a kind of “God’s eye” point of view. To the experimentalist, the “true” probabilities  $p_1, \dots, p_k$  will very often be *unknown* at the outset. Thus, his burden is to estimate the unknown probabilities by a statistical analysis of the experiment’s outcomes.

In the Bayesian approach, however, it does not make sense to talk about estimating a true probability. Instead, a Bayesian assigns a prior probability distribution  $p(x_1, x_2, \dots, x_N)$  on the multi-trial hypothesis space and uses Bayes’ theorem to update the distribution in the light of his measurement results. The content of de Finetti’s theorem is this. Assuming *only* that

$$p(x_{\pi(1)}, x_{\pi(2)}, \dots, x_{\pi(N)}) = p(x_1, x_2, \dots, x_N) \quad (129)$$

for any permutation  $\pi$  of the set  $\{1, \dots, N\}$ , and that for any integer  $M > 0$ , there is a distribution  $p_{N+M}(x_1, x_2, \dots, x_{N+M})$  with the same permutation property such that

$$p(x_1, x_2, \dots, x_N) = \sum_{x_{N+1}, \dots, x_{N+M}} p_{N+M}(x_1, \dots, x_N, x_{N+1}, \dots, x_{N+M}) , \quad (130)$$

then  $p(x_1, x_2, \dots, x_N)$  can be written uniquely in the form

$$\begin{aligned} p(x_1, x_2, \dots, x_N) &= \int_{\mathcal{S}_k} P(\vec{p}) p_{x_1} p_{x_2} \cdots p_{x_N} d\vec{p} \\ &= \int_{\mathcal{S}_k} P(\vec{p}) p_1^{n_1} p_2^{n_2} \cdots p_k^{n_k} d\vec{p} , \end{aligned} \quad (131)$$

where  $\vec{p} = (p_1, p_2, \dots, p_k)$ , and the integral is taken over the simplex of such distributions

$$\mathcal{S}_k = \left\{ \vec{p} : p_j \geq 0 \text{ for all } j \text{ and } \sum_{j=1}^k p_j = 1 \right\} . \quad (132)$$

Furthermore, the function  $P(\vec{p}) \geq 0$  is required to be a probability density function on the simplex:

$$\int_{\mathcal{S}_k} P(\vec{p}) d\vec{p} = 1 , \quad (133)$$

With this representation theorem, the unsatisfactory concept of an unknown probability vanishes from the description in favor of the fundamental idea of assigning an exchangeable probability distribution to multiple trials.

With this cue in hand, it is easy to see how to reword the description of quantum-state tomography to meet our goals. What is relevant is simply a judgment on the part of the experimenter—notice the essential subjective character of this “judgment”—that there is no distinction between the systems the device is preparing. In operational terms, this is the judgment that *all the systems are and will be the same as far as observational predictions are concerned*. At first glance this statement might seem to be contentless, but the important point is this: To make this statement, one need never use the notion of an unknown state—a completely operational description is good

enough. Putting it into technical terms, the statement is that if the experimenter judges a collection of  $N$  of the device’s outputs to have an overall quantum state  $\rho^{(N)}$ , he will also judge any permutation of those outputs to have the same quantum state  $\rho^{(N)}$ . Moreover, he will do this no matter how large the number  $N$  is. This, complemented only by the consistency condition that for any  $N$  the state  $\rho^{(N)}$  be derivable from  $\rho^{(N+1)}$ , makes for the complete story.

The words “quantum state” appear in this formulation, just as in the original formulation of tomography, but there is no longer any mention of *unknown* quantum states. The state  $\rho^{(N)}$  is known by the experimenter (if no one else), for it represents his judgment. More importantly, the experimenter is in a position to make an unambiguous statement about the structure of the whole sequence of states  $\rho^{(N)}$ : Each of the states  $\rho^{(N)}$  has a kind of permutation invariance over its factors. The content of the *quantum de Finetti representation theorem* [32, 105] is that a sequence of states  $\rho^{(N)}$  can have these properties, which are said to make it an *exchangeable* sequence, if and only if each term in it can also be written in the form

$$\rho^{(N)} = \int_{\mathcal{D}_D} P(\rho) \rho^{\otimes N} d\rho, \quad (134)$$

where  $\rho^{\otimes N} = \rho \otimes \rho \otimes \cdots \otimes \rho$  is an  $N$ -fold tensor product. Here  $P(\rho) \geq 0$  is a fixed probability distribution over the density operator space  $\mathcal{D}_D$ , and

$$\int_{\mathcal{D}_D} P(\rho) d\rho = 1, \quad (135)$$

where  $d\rho$  is a suitable measure.

The interpretive import of this theorem is paramount. For it alone gives a mandate to the term unknown state in the usual description of tomography. It says that the experimenter can act *as if* his judgment  $\rho^{(N)}$  comes about because he knows there is a “man in the box,” hidden from view, repeatedly preparing the same state  $\rho$ . He does not know which such state, and the best he can say about the unknown state is captured in the probability distribution  $P(\rho)$ .

The quantum de Finetti theorem furthermore makes a connection to the overarching theme of Bayesianism stressed above. It guarantees for two independent observers—as long as they have a rather minimal agreement in their initial beliefs—that the outcomes of a sufficiently informative set of measurements will force a convergence in their state assignments for the remaining systems [33]. This “minimal” agreement is characterized by a judgment on the part of both parties that the sequence of systems is exchangeable, as described above, and a promise that the observers are not absolutely inflexible in their opinions. Quantitatively, the latter means that though  $P(\rho)$  may be arbitrarily close to zero, it can never vanish.

This coming to agreement works because an exchangeable density operator sequence can be updated to reflect information gathered from measurements by another quantum version of Bayes’s rule for updating probabilities [33]. Specifically, if measurements on  $K$  systems yield results  $D_K$ , then the state of additional systems is constructed as in Eq. (134), but using an updated probability on density operators given by

$$P(\rho|D_K) = \frac{P(D_K|\rho)P(\rho)}{P(D_K)}. \quad (136)$$

Here  $P(D_K|\rho)$  is the probability to obtain the measurement results  $D_K$ , given the state  $\rho^{\otimes K}$  for the  $K$  measured systems, and

$$P(D_K) = \int_{\mathcal{D}_D} P(D_K|\rho) P(\rho) d\rho \quad (137)$$

is the unconditional probability for the measurement results. For a sufficiently informative set of measurements, as  $K$  becomes large, the updated probability  $P(\rho|D_K)$  becomes highly peaked on a particular state  $\rho_{D_K}$  dictated by the measurement results, regardless of the prior probability  $P(\rho)$ , as long as  $P(\rho)$  is nonzero in a neighborhood of  $\rho_{D_K}$ . Suppose the two observers have different initial beliefs, encapsulated in different priors  $P_i(\rho)$ ,  $i = 1, 2$ . The measurement results force them to a common state of belief in which any number  $N$  of additional systems are assigned the product state  $\rho_{D_K}^{\otimes N}$ , i.e.,

$$\int P_i(\rho|D_K) \rho^{\otimes N} d\rho \longrightarrow \rho_{D_K}^{\otimes N}, \quad (138)$$

independent of  $i$ , for  $K$  sufficiently large.

This shifts the perspective on the purpose of quantum-state tomography: It is not about uncovering some “unknown state of nature,” but rather about the various observers’ coming to agreement over future probabilistic predictions. In this connection, it is interesting to note that the quantum de Finetti theorem and the conclusions just drawn from it work only within the framework of complex vector-space quantum mechanics. For quantum mechanics based on real Hilbert spaces [106], the connection between exchangeable density operators and unknown quantum states does not hold.

A simple counterexample is the following. Consider the  $N$ -system state

$$\rho^{(N)} = \frac{1}{2}\rho_+^{\otimes N} + \frac{1}{2}\rho_-^{\otimes N}, \quad (139)$$

where

$$\rho_+ = \frac{1}{2}(I + \sigma_2) \quad \text{and} \quad \rho_- = \frac{1}{2}(I - \sigma_2) \quad (140)$$

and  $\sigma_1$ ,  $\sigma_2$ , and  $\sigma_3$  are the Pauli matrices. In complex-Hilbert-space quantum mechanics, Eq. (139) is clearly a valid density operator: It corresponds to an equally weighted mixture of  $N$  spin-up particles and  $N$  spin-down particles in the  $y$ -direction. The state  $\rho^{(N)}$  is thus exchangeable, and the decomposition in Eq. (139) is unique according to the quantum de Finetti theorem.

But now consider  $\rho^{(N)}$  as an operator in real-Hilbert-space quantum mechanics. Despite its ostensible use of the imaginary number  $i$ , it remains a valid quantum state. This is because, upon expanding the right-hand side of Eq. (139), all the terms with an odd number of  $\sigma_2$ ’s cancel away. Yet, even though it is an exchangeable density operator, it cannot be written in de Finetti form Eq. (134) using only real symmetric operators. This follows because  $i\sigma_2$  cannot be written as a linear combination of  $I$ ,  $\sigma_1$ , and  $\sigma_3$ , while a real-Hilbert-space de Finetti expansion as in Eq. (134) can *only* contain those three operators. Hence the de Finetti theorem does not hold in real-Hilbert-space quantum mechanics.

In classical probability theory, exchangeability characterizes those situations where the only data relevant for updating a probability distribution are frequency data, i.e., the numbers  $n_j$  in Eq. (131). The quantum de Finetti representation shows that the same is true in quantum mechanics: Frequency data (with respect to a sufficiently robust measurement, in particular, any one that is informationally complete) are sufficient for updating an exchangeable state to the point where nothing more can be learned from sequential measurements. That is, one obtains a convergence of the form Eq. (138), so that ultimately any further measurements on the individual systems will be statistically independent. That there is no quantum de Finetti theorem in real Hilbert space means that there are fundamental differences between real and complex Hilbert spaces with respect to learning from measurement results.

Finally, in summary, let us hang on the point of learning for just a little longer. The quantum de Finetti theorem shows that the essence of quantum-state tomography is not in revealing an

“element of reality” but in deriving that various agents (who agree some minimal amount) can come to agreement in their ultimate quantum-state assignments. This is not at all the same thing as the statement “reality does not exist.” It is simply that one need not go to the extreme of taking the “unknown quantum state” as being objectively real to make sense of the experimental practice of tomography.

J. M. Bernardo and A. F. M. Smith in their book Ref. [77] word the goal of these exercises we have run through in this paper very nicely:

[I]ndividual degrees of belief, expressed as probabilities, are inescapably the starting point for descriptions of uncertainty. There can be no theories without theoreticians; no learning without learners; in general, no science without scientists. It follows that learning processes, whatever their particular concerns and fashions at any given point in time, are necessarily reasoning processes which take place in the minds of individuals. To be sure, the object of attention and interest may well be an assumed external, objective reality: but the actuality of the learning process consists in the evolution of individual, subjective beliefs about that reality. However, it is important to emphasize . . . that the primitive and fundamental notions of *individual* preference and belief will typically provide the starting point for *interpersonal* communication and reporting processes. . . . [W]e shall therefore often be concerned to identify and examine features of the individual learning process which relate to interpersonal issues, such as the conditions under which an approximate consensus of beliefs might occur in a population of individuals.

The quantum de Finetti theorem provides a case in point for how much agreement a population can come to from within quantum mechanics.

One is left with a feeling—an almost salty feeling—that perhaps this is the whole point of the structure of quantum mechanics. Perhaps the missing ingredient for narrowing the structure of Bayesian probability down to quantum mechanics has been in front of us all along. It finds no better expression than in taking account of the challenges the physical world poses to our coming to agreement.

## 10 The Oyster and the Quantum

The significance of this development is to give us insight into the logical possibility of a new and wider pattern of thought. This takes into account the observer, including the apparatus used by him, differently from the way it was done in classical physics . . . In the new pattern of thought we do not assume any longer the *detached observer*, occurring in the idealizations of this classical type of theory, but an observer who by his indeterminable effects creates a new situation, theoretically described as a new state of the observed system. . . . In this way every observation is a singling out of a particular factual result, here and now, from the theoretical possibilities, thereby making obvious the discontinuous aspect of the physical phenomena.

Nevertheless, there remains still in the new kind of theory an *objective reality*, inasmuch as these theories deny any possibility for the observer to influence the results of a measurement, once the experimental arrangement is chosen. Particular qualities of an individual observer do not enter the conceptual framework of the theory.

— Wolfgang Pauli, 1954



A grain of sand falls into the shell of an oyster and the result is a pearl. The oyster’s sensitivity to the touch is the source a beautiful gem. In the 75 years that have passed since the founding of quantum mechanics, only the last 10 have turned to a view and an attitude that may finally reveal the essence of the theory. The quantum world is sensitive to the touch, and that may be one of the best things about it. Quantum information—with its three specializations of quantum information theory, quantum cryptography, and quantum computing—leads the way in telling us how to quantify that idea. Quantum algorithms can be exponentially faster than classical algorithms. Secret keys can be encoded into physical systems in such a way as to reveal whether information has been gathered about them. The list of triumphs keeps growing.

The key to so much of this has been simply in a change of attitude. This can be seen by going back to almost any older textbook on quantum mechanics: Nine times out of ten, the Heisenberg uncertainty relation is presented in a way that conveys the feeling that we have been short-changed by the physical world.

“Look at classical physics, how nice it is: We can measure a particle’s position and momentum with as much accuracy as we would like. How limiting quantum theory is instead. We are stuck with

$$\Delta x \Delta p \geq \frac{1}{2} \hbar ,$$

and there is nothing we can do about it. The task of physics is to sober up to this state of affairs and make the best of it.”

How this contrasts with the point of departure of quantum information! There the task is not to ask what limits quantum mechanics places upon us, but what novel, productive things we can do in the quantum world that we could not have done otherwise. In what ways is the quantum world fantastically better than the classical one?

If one is looking for something “real” in quantum theory, what more direct tack could one take than to look to its technologies? People may argue about the objective reality of the wave function ad infinitum, but few would argue about the existence of quantum cryptography as a solid prediction of the theory. Why not take that or a similar effect as the grounding for what quantum mechanics is trying to tell us about nature?

Let us try to give this imprecise set of thoughts some shape by reexpressing quantum cryptography in the language built up in the previous sections. For quantum key distribution it is essential to be able to prepare a physical system in one or another quantum state drawn from some fixed *nonorthogonal* set [102, 107]. These nonorthogonal states are used to encode a potentially secret cryptographic key to be shared between the sender and receiver. The information an eavesdropper seeks is about which quantum state was actually prepared in each individual transmission. What is novel here is that the encoding of the proposed key into nonorthogonal states forces the information-gathering process to induce a disturbance to the overall *set* of states. That is, the presence of an active eavesdropper transforms the initial pure states into a set of mixed states or, at the very least, into a set of pure states with larger overlaps than before. This action ultimately boils down to a loss of predictability for the sender over the outcomes of the receiver’s measurements and, so, is directly detectable by the receiver (who reveals some of those outcomes for the sender’s inspection). More importantly, there is a direct connection between the statistical information gained by an eavesdropper and the consequent disturbance she must induce to the quantum states in the process. As the information gathered goes up, the necessary disturbance also goes up in a precisely formalizable way [108, 109].

Note the two ingredients that appear in this scenario. First, the information gathering or measurement is grounded with respect to one observer (in this case, the eavesdropper), while the

disturbance is grounded with respect to another (here, the sender). In particular, the disturbance is a disturbance to the sender’s previous information—this is measured by her diminished ability to predict the outcomes of certain measurements the legitimate receiver might perform. No hint of any variable intrinsic to the system is made use of in this formulation of the idea of “measurement causing disturbance.”

The second ingredient is that one must consider at least two possible nonorthogonal preparations in order for the formulation to have any meaning. This is because the information gathering is not about some classically-defined observable—i.e., about some unknown hidden variable or reality intrinsic to the system—but is instead about which of the unknown states the sender actually prepared. The lesson is this: Forget about the unknown preparation, and the random outcome of the quantum measurement is information about nothing. It is simply “quantum noise” with no connection to any preexisting variable.

How crucial is this second ingredient—that is, that there be at least two nonorthogonal states within the set under consideration? We can address its necessity by making a shift in the account above: One might say that the eavesdropper’s goal is not so much to uncover the identity of the unknown quantum state, but to sharpen her predictability over the receiver’s measurement outcomes. In fact, she would like to do this at the same time as disturbing the sender’s predictions as little as possible. Changing the language still further to the terminology of Section 4, the eavesdropper’s actions serve to sharpen her information about the potential consequences of the receiver’s further interventions on the system. (Again, she would like to do this while minimally diminishing the sender’s previous information about those same consequences.) In the cryptographic context, a byproduct of this effort is that the eavesdropper ultimately comes to a more sound prediction of the secret key. From the present point of view, however, the importance of this change of language is that it leads to an almost Bayesian perspective on the information–disturbance problem.

As previously emphasized, within Bayesian probability the most significant theme is to identify the conditions under which a set of decision-making agents can come to a common probability assignment for some random variable in spite of the fact that their initial probabilities differ [77]. One might similarly view the process of quantum eavesdropping. The sender and the eavesdropper start off initially with differing quantum state assignments for a single physical system. In this case it so happens that the sender can make sharper predictions than the eavesdropper about the outcomes of the receiver’s measurements. The eavesdropper, not satisfied with this situation, performs a measurement on the system in an attempt to sharpen those predictions. In particular, there is an attempt to come into something of an agreement with the sender but without revealing the outcomes of her measurements or, indeed, her very presence.

It is at this point that a distinct *property* of the quantum world makes itself known. The eavesdropper’s attempt to surreptitiously come into alignment with the sender’s predictability is always shunted away from its goal. This shunting of various observer’s predictability is the subtle manner in which the quantum world is sensitive to our experimental interventions.

And maybe this is our crucial hint! The wedge that drives a distinction between Bayesian probability theory in general and quantum mechanics in particular is perhaps nothing more than this “Zing!” of a quantum system that is manifested when an agent interacts with it. It is this wild sensitivity to the touch that keeps our information and beliefs from ever coming into too great of an alignment. The most our beliefs about the potential consequences of our interventions on a system can come into alignment is captured by the mathematical structure of a pure quantum state  $|\psi\rangle$ . Take all possible information–disturbance curves for a quantum system, tie them into a bundle, and *that* is the long-awaited property, the input we have been looking for from nature. Or, at least, that is the speculation.

## 10.1 Give Us a Little Reality

What we need here is a little Reality.  
— *Herbert Bernstein*, circa 1997

In the previous version of this paper [1] I ended the discussion just at this point with the following words, “Look at that bundle long and hard and we might just find that it stays together without the help of our tie.” But I imagine that wispy command was singularly unhelpful to anyone who wanted to pursue the program further.

How might one hope to mathematize the bundle of all possible information-disturbance curves for a system? If it can be done at all, the effort will have to end up depending upon a single real parameter—the dimension of the system’s Hilbert space. As a safety check, let us ask ourselves right at the outset whether this is a tenable possibility? Or will Hilbert-space dimension go the wayside of subjectivity, just as we saw so many of the other terms in the theory go? I think the answer will be in the negative: Hilbert-space dimension will survive to be a stand-alone concept with no need of an agent for its definition.

The simplest check perhaps is to pose the same Einsteinian test for it as we did first for the quantum state and then for quantum time evolutions. Posit a bipartite system with Hilbert spaces  $\mathcal{H}_{D_1}$  and  $\mathcal{H}_{D_2}$  (with dimensions  $D_1$  and  $D_2$  respectively) and imagine an initial quantum state for that bipartite system. As argued too many times already, the quantum state must be a subjective component in the theory because the theory allows localized measurements on the  $D_1$  system to change the quantum state for the  $D_2$  system. In contrast, is there anything one can do at the  $D_1$  site to change the numerical value of  $D_2$ ? It does not appear so. Indeed, the only way to change that number is to scrap the initial supposition. Thus, to that extent, one has every right to call the numbers  $D_1$  and  $D_2$  potential “elements of reality.”

It may not look like much, but it is a start.<sup>44</sup> And one should not belittle the power of a good hint, no matter how small.<sup>45</sup>

## 11 Appendix: Changes Made Since quant-ph/0106166 Version

Beside overhauling the Introduction so as to make it more relevant to the present meeting, I made the following more substantive changes to the old version:

1. I made the language slightly less flowery throughout.
2. Some of the jokes are now explained for the readers who thought they were typographical errors.
3. For the purpose of Section 1’s imagery, I labeled the followers of the Spontaneous Collapse and Many-Worlds interpretations, Spontaneous Collapseans and Everettics—in contrast to the previous terms Spontaneous Collapsicans and Everettistas—to better emphasize their religious aspects.
4. Some figures were removed from the quantum de Finetti section and the *dramatis personae* on page 2 was added.
5. I now denote the outcomes of a general POVM by the index  $d$  to evoke the image that all (and only) a quantum measurement ever does is gather a piece of *data* by which we update our subjective probabilities for something else. It causes us to change our subjective probability

---

<sup>44</sup>Cf. also Ref. [110].

<sup>45</sup>Cf. also the final paragraphs of Section 1.

assignments  $P(h)$  for some hypothesis  $h$  to a posterior assignment  $P_d(h)$  conditioned on the data  $d$ .

6. As noted in Footnote 9, this paper is a bit of a transitional one for me in that, since writing [quant-ph/0106166](#), I have become much more convinced of the consistency and value of the “radically” subjective Bayesian paradigm for probability theory. That is, I have become much more inclined to the view of Bruno de Finetti [104], say, than that of Edwin Jaynes [111]. To that end, I have stopped calling probability distributions “states of knowledge” and been more true to the conception that they are “states of belief” whose cash-value is determined by the way an agent will gamble in light of them. That is, a probability distribution, once it is written down, is very literally a gambling commitment the writer of it uses with respect to the phenomenon he is describing. It is not clear to what extent this adoption of terminology will cause obfuscation rather than clarity in the present paper; it was certainly not needed for many of the discussions. Still I could not stand to propagate my older view any further.
7. In general, 23 footnotes, 38 equations, and over 43 references have been added. There are five new historical quotes starting the sections, and the ghostly quote of Section 9 has been modified for greater accuracy.
8. The metaphor ending Section 1, describing how the grail of the present quantum foundations program can be likened to the spacetime manifold of general relativity, is new.
9. Section 2 has been expanded to be consistent with the rest of the paper. Also, there are three important explanatory footnotes to be found there.
10. Einstein’s letter to Michele Besso in Section 3 is now quoted in full.
11. Section 4.1, which argues more strongly for Gleason’s noncontextuality assumption than previously, is new.
12. Section 4.2, which explains informationally complete POVMs and uses them to imagine a “standard quantum measurement” at the Bureau of Weights and Measures, is new.
13. To elaborate the connection between entanglement and the standard probability rule, I switched the order of presentation of the “Whither Bayes Rule?” and “Wither Entanglement?” sections.
14. The technical mistake that was in Section 5 is now deleted. The upshot of the old argument, however, remains: The tensor-product rule for combining quantum systems can be thought of as secondary to the structure of local observables.
15. A much greater elaboration of the “classical measurement problem”—i.e., the mystery of *physical* cause of Bayesian conditionalization upon the acquisition of new information (or the lack of a mystery thereof)—is now given in Section 6.
16. Section 6.1, wherein a more detailed description of the relation between real-world measurements and the hypothetical standard quantum measurement is fleshed out, is new.
17. Section 7, which argues for the nonreality of the Hamiltonian and the necessary subjectivity of the ascription of a POVM to a measurement device, is new.
18. Section 8, wherein I find a way to use the word bloodbath, is new.
19. The long quote in Section 9 by Bernardo and Smith, which describes what Bayesian probability theory strives for, is new. Here’s another good quote of theirs that didn’t fit in anywhere else:

What is the nature and scope of Bayesian Statistics within this spectrum of activity?

Bayesian Statistics offers a rationalist theory of personalistic beliefs in contexts of uncertainty, with the central aim of characterising how an individual should act in order to avoid certain kinds of undesirable behavioural inconsistencies. The theory establishes that expected utility maximization provides the basis for rational decision making and that Bayes' theorem provides the key to the ways in which beliefs should fit together in the light of changing evidence. The goal, in effect, is to establish rules and procedures for individuals concerned with disciplined uncertainty accounting. The theory is not descriptive, in the sense of claiming to model actual behaviour. Rather, it is prescriptive, in the sense of saying "if you wish to avoid the possibility of these undesirable consequences you must act in the following way."

- 20. Section 10.1, which argues for the nonsubjectivity of Hilbert-space dimension, is new.
- 21. One can read about the term "Reality" in Ref. [112].

## 12 Acknowledgments

I thank Carl Caves, Greg Comer, David Mermin, and Rüdiger Schack for the years of correspondence that led to this view, Jeff Bub and Lucien Hardy for giving me courage in general, Adán Cabello, Asher Peres, and Arkady Plotnitsky for their help in compiling the dramatis personae of the Introduction, Jeff Nicholson for composing the paper's figures, and Andrei Khrennikov for infinite patience. Further thanks go to Charlie Bennett, Matthew Donald, Steven van Enk, Jerry Finkelstein, Philippe Grangier, Osamu Hirota, Andrew Landahl, Hideo Mabuchi, Jim Malley, Mike Nielsen, Masanao Ozawa, John Preskill, Terry Rudolph, Johann Summhammer, Chris Timpson, and Alex Wilce for their many comments on the previous version of this paper—all of which I tried to respond to in some shape or fashion—and particularly warm gratitude goes to Howard Barnum for pointing out my technical mistake in the "Wither Entanglement?" section. Finally, I thank Ulrich Mohrhoff for calling me a Kantian; it taught me that I should work a little harder to make myself look Jamesian.

## References

- [1] C. A. Fuchs, "Quantum Foundations in the Light of Quantum Information," in *Decoherence and its Implications in Quantum Computation and Information Transfer: Proceedings of the NATO Advanced Research Workshop, Mykonos Greece, June 25–30, 2000*, edited by A. Gonis and P. E. A. Turchi (IOS Press, Amsterdam, 2001), pp. 38–82. Also posted at [quant-ph/0106166](http://quant-ph/0106166).
- [2] C. A. Fuchs, "Quantum States: What the Hell Are They? (*The Post-Växjö Phase Transition*)," posted at <http://netlib.bell-labs.com/who/cafuchs/>.
- [3] J. T. Cushing, A. Fine, and S. Goldstein, editors, *Bohmian Mechanics and Quantum Theory: An Appraisal*, (Kluwer, Dordrecht, 1996).
- [4] R. B. Griffiths and R. Omnès, "Consistent Histories and Quantum Measurements," *Phys. Today* **52**(8), 26–31 (1999).
- [5] J. G. Cramer, "An Overview of the Transactional Interpretation of Quantum Mechanics," *Int. J. Theor. Phys.* **27**, 227–236 (1988).
- [6] G. C. Ghirardi and P. Pearle, "Dynamical Reduction Theories: Changing Quantum Theory so the Statevector Represents Reality," *PSA 1990: Proceedings of the Biennial Meeting of the Philosophy of Science Association, Vol. I*, edited by A. Fine, M. Forbes, and L. Wessels (Philosophy of Science Association, East Lansing, MI, 1990), pp. 19–34.

- [7] W. H. Zurek, “Decoherence, Einselection and the Existential Interpretation (The Rough Guide),” *Phil. Trans. R. Soc. Lond. A* **356**, 1793–1821 (1998).
- [8] P. Grangier, “Contextual Objectivity: A Realistic Interpretation of Quantum Mechanics,” [quant-ph/0012122](#); P. Grangier, “Reconstructing the Formalism of Quantum Mechanics in the ‘Contextual Objectivity’ Point of View,” [quant-ph/0111154](#).
- [9] D. Deutsch, *The Fabric of Reality: The Science of Parallel Universes—and its Implications*, (Allen Lane, New York, 1997).
- [10] L. Vaidman, “The Many-Worlds Interpretation of Quantum Mechanics,” in *The Stanford Encyclopedia of Philosophy (Summer 2002 Edition)*, edited by E. N. Zalta (Stanford University, Stanford, CA, 2002). Available at <http://plato.stanford.edu/entries/qm-manyworlds/>.
- [11] C. Rovelli, “Relational Quantum Mechanics,” *Int. J. Theor. Phys.* **35**, 1637–1678 (1996).
- [12] R. W. Clark, *Einstein: The Life and Times*, (World Publishing Co., New York, 1971). See Chapter 10:
- [T]hey created the “Study Group of German Natural Philosophers” . . . which had at its disposal large sums of money, offered fees to those who would write or speak against Einstein, and advertised its meetings by large posters as though there were announcing public concerts. . . . In August the “Antirelativity Company,” as Einstein called it, announced twenty meetings to be held in Germany’s biggest towns.
- [13] M. Gardner, *Relativity for the Million*, (Macmillan, New York, 1962).
- [14] B. S. DeWitt and R. N. Graham, “Resource Letter IQM-1 on the Interpretation of Quantum Mechanics,” *Am. J. Phys.* **39**, 724–738 (1971).
- [15] W. James, “The Sentiment of Rationality,” in *The Writings of William James: A Comprehensive Edition*, edited with an introduction by J. J. McDermott (Modern Library, Random House, New York, 1967), pp. 317–345.
- [16] C. W. Misner, K. S. Thorne, and J. A. Wheeler, *Gravitation*, (W. H. Freeman, San Francisco, 1973), p. 23.
- [17] A. Zeilinger, “A Foundational Principle for Quantum Mechanics,” *Found. Phys.* **29**, 631–643 (1999); C. Brukner and A. Zeilinger, “Operationally Invariant Information in Quantum Measurements,” *Phys. Rev. Lett.* **83**, 3354–3357 (1999); C. Brukner and A. Zeilinger, “Conceptual Inadequacy of the Shannon Information in Quantum Measurements,” *Phys. Rev. A* **63**, 022113-1–022113-10 (2001); C. Brukner, M. Zukowski, and A. Zeilinger, “The Essence of Entanglement,” [quant-ph/0106119](#); M. J. W. Hall, “Comment on ‘Conceptual Inadequacy of Shannon Information . . .’ by C. Brukner and A. Zeilinger,” [quant-ph/0007116](#); C. G. Timpson, “On the Supposed Conceptual Inadequacy of the Shannon Information,” [quant-ph/0112178](#).
- [18] I. Devetak and A. E. Staples, “Towards a Unification of Physics and Information Theory,” [quant-ph/0112166](#).
- [19] N. D. Mermin, “The Contemplation of Quantum Computation,” *Phys. Tod.* **53**(7), 11–12 (2000).
- [20] H. Barnum, “Quantum Information Processing and Quantum Logic: Towards Mutual Illumination,” [quant-ph/0205129](#).
- [21] P. Grangier, private communication, 2001.
- [22] C. H. Bennett, T. A. Brun, C. M. Caves, and N. D. Mermin, various vibes, 2001.
- [23] C. H. Bennett, G. Brassard, C. Crépeau, R. Jozsa, A. Peres, and W. K. Wootters, “Teleporting an Unknown Quantum State via Dual Classical and Einstein-Podolsky-Rosen Channels,” *Phys. Rev. Lett.* **70**, 1895 (1993).
- [24] J. Bub, “Quantum Mechanics as a Principle Theory,” *Stud. Hist. Phil. Mod. Phys.* **31**, 74–95 (2000).
- [25] J. Bub, *Interpreting the Quantum World*, (Cambridge University Press, Cambridge, 1997).
- [26] J. S. Bell, *Speakable and Unspeakable in Quantum Mechanics: Collected Papers on Quantum Philosophy* (Cambridge U. Press, Cambridge, 1987).

- [27] M. A. Nielsen and I. L. Chuang, *Quantum Computation and Quantum Information*, (Cambridge University Press, Cambridge, 2000).
- [28] P. Busch, “Quantum States as Effect Valuations: Giving Operational Content to von Neumann’s No-Hidden-Variables Theorem,” [quant-ph/9909073](#).
- [29] C. M. Caves, C. A. Fuchs, K. Manne, and J. Renes, “Gleason’s Theorem with POVMs,” unpublished, 2000.
- [30] A. M. Gleason, “Measures on the Closed Subspaces of a Hilbert Space,” *J. Math. Mech.* **6**, 885–894 (1957).
- [31] K. Vogel and H. Risken, “Determination of Quasiprobability Distributions in Terms of Probability Distributions for the Rotated Quadrature Phase,” *Phys. Rev. A* **40**, 2847 (1989); U. Leonhardt, “Quantum-State Tomography and Discrete Wigner Function,” *Phys. Rev. Lett.* **74**, 4101 (1995).
- [32] C. M. Caves, C. A. Fuchs and R. Schack, “Unknown Quantum States: The Quantum de Finetti Representation,” to appear in *J. Math. Phys.* (2002). See [quant-ph/0104088](#).
- [33] R. Schack, T. A. Brun, and C. M. Caves, “Quantum Bayes Rule,” *Phys. Rev. A* **64**, 014305-1–014305-4 (2001).
- [34] A. Einstein, B. Podolsky, and N. Rosen, “Can Quantum-Mechanical Description of Physical Reality Be Considered Complete?,” *Phys. Rev.* **47**, 777–780 (1935).
- [35] A. Fine, *The Shaky Game: Einstein Realism and the Quantum Theory*, (University of Chicago Press, Chicago, 1986); M. Jammer, “The EPR Problem in Its Historical Development,” in *Symposium on the Foundations of Modern Physics: 50 years of the Einstein-Podolsky-Rosen Gedankenexperiment*, edited by P. Lahti and P. Mittelstaedt (World Scientific, Singapore, 1985), pp. 129–149.
- [36] L. P. Hughston, R. Jozsa, and W. K. Wootters, “A Complete Classification of Quantum Ensembles Having a Given Density Matrix,” *Phys. Lett. A* **183**, 14–18 (1993).
- [37] J. Bernstein, *Quantum Profiles*, (Princeton University Press, Princeton, NJ, 1991).
- [38] A. Einstein, “Remarks Concerning the Essays Brought Together in this Co-Operative Volume,” in *Albert Einstein: Philosopher-Scientist*, third edition, edited by P. A. Schilpp (Open Court, La Salle, IL, 1970), pp. 665–688.
- [39] A. Peres, *Quantum Theory: Concepts and Methods*, (Kluwer, Dordrecht, 1993).
- [40] C. M. Caves and C. A. Fuchs, “Quantum Information: How Much Information in a State Vector?,” in *The Dilemma of Einstein, Podolsky and Rosen – 60 Years Later*, edited by A. Mann and M. Revzen, *Ann. Israel Phys. Soc.* **12**, 226–257 (1996).
- [41] W. Pauli, letter to M. Fierz dated 10 August 1954, reprinted and translated in K. V. Laurikainen, *Beyond the Atom: The Philosophical Thought of Wolfgang Pauli*, (Springer-Verlag, Berlin, 1988), p. 226.
- [42] R. Penrose, *The Emperor’s New Mind: Concerning Computers, Minds, and the Laws of Physics*, (Oxford University Press, Oxford, 1989), pp. 268–269.
- [43] L. J. Savage, *The Foundations of Statistics*, (Dover, New York, 1954).
- [44] M. Jammer, “The Experiment in Classical and in Quantum Physics,” in *Proceedings of the International Symposium, Foundations of Quantum Mechanics in the Light of New Technology*, edited by S. Kamefuchi, H. Ezawa, Y. Murayama, M. Namiki, S. Nomura, Y. Ohnuki, and T. Yajima (Physical Society of Japan, Tokyo, 1984), pp. 265–276.
- [45] W. Heisenberg, *Physics and Beyond: Encounters and Conversations*, translated by A. J. Pomerans (Harper & Row, New York, 1971), pp. 63–64.
- [46] C. A. Fuchs and A. Peres, “Quantum Theory Needs No ‘Interpretation’,” *Phys. Today* **53**(3), 70 (2000); “Quantum Theory – Interpretation, Formulation, Inspiration: Fuchs and Peres Reply,” **53**(9), 14 (2000).
- [47] P. Simon, “Kathy’s Song,” (Columbia Records, New York, 1965).

- [48] H. Barnum, C. M. Caves, J. Finkelstein, C. A. Fuchs, and R. Schack, “Quantum Probability from Decision Theory?,” *Proc. Roy. Soc. Lond. A* **456**, 1175–1182 (2000).
- [49] R. Cooke, M. Keane, and W. Moran, “An Elementary Proof of Gleason’s Theorem,” *Math. Proc. Camb. Phil. Soc.* **98**, 117–128 (1981); I. Pitowsky, “Infinite and Finite Gleason’s Theorems and the Logic of Indeterminacy,” *J. Math. Phys.* **39**, 218–228 (1998).
- [50] K. Kraus, *States, Effects, and Operations. Fundamental Notions of Quantum Theory* (Springer, Berlin, 1983), Lecture Notes in Physics Vol. 190.
- [51] A. S. Holevo, “Information-Theoretical Aspects of Quantum Measurement,” *Prob. Info. Trans.* **9**, 110–118 (1973).
- [52] S. J. van Enk, “Quantum and Classical Game Strategies,” *Phys. Rev. Lett.* **84**, 789 (2000).
- [53] C. A. Fuchs and J. Renes, “Kochen-Specker-like Noncolorability for Trine Measurements on a Qubit,” long overdue, but still in preparation.
- [54] D. A. Meyer, “Finite Precision Measurement Nullifies the Kochen-Specker Theorem,” *Phys. Rev. Lett.* **83**, 3751–3754 (1999); A. Kent, “Non-Contextual Hidden Variables and Physical Measurements,” *Phys. Rev. Lett.* **83** 3755–3757 (1999).
- [55] I thank Howard Barnum for pointing out the similarities between this line of thought and that in G. W. Mackey, *Mathematical Foundations of Quantum Mechanics*, (W. A. Benjamin, New York, 1963), pp. 62–63.
- [56] C. A. Fuchs, *Notes on a Paulian Idea: Foundational, Historical, Anecdotal and Forward-Looking Thoughts on the Quantum*, [quant-ph/0105039](https://arxiv.org/abs/quant-ph/0105039).
- [57] N. E. Baytch and C. A. Fuchs, “Nonorthogonal Variations of Gleason’s Theorem in Quantum Mechanics,” forthcoming.
- [58] L. Hardy, “Quantum Theory From Five Reasonable Axioms,” [quant-ph/0101012](https://arxiv.org/abs/quant-ph/0101012).
- [59] L. Hardy, “Why Quantum Theory?,” to appear in *Proceedings of the NATO Advanced Research Workshop on Modality, Probability, and Bell’s Theorem*, edited by J. Butterfield and T. Placek (IOS Press, Amsterdam, 2002), [quant-ph/0111068](https://arxiv.org/abs/quant-ph/0111068).
- [60] E. Prugovečki, “Information-Theoretical Aspects of Quantum Measurements,” *Int. J. Theor. Phys.* **16**, 321 (1977).
- [61] F. E. Schroeck, Jr., “Coexistence of Observables,” *Int. J. Theor. Phys.* **28**, 247–262 (1989); F. E. Schroeck, Jr., “Unsharpness in Measurement Yields Informational Completeness,” in *Symposium on the Foundations of Modern Physics 1990: Quantum Theory of Measurement and Related Philosophical Problems*, edited by P. Lahti and P. Mittelstaedt (World Scientific, Singapore, 1991), pp. 375–389; F. E. Schroeck, Jr., B. Fischer, and G. Harnett, “Informational Completeness and Frames,” in *Symposium on the Foundations of Modern Physics 1993: Quantum Measurement, Irreversibility and the Physics of Information*, edited by P. Busch, P. Lahti, and P. Mittelstaedt (World Scientific, Singapore, 1993), pp. 378–389.
- [62] P. Busch, “Informationally Complete Sets of Physical Quantities,” *Int. J. Theor. Phys.* **30**, 1217–1227 (1991).
- [63] C. A. Fuchs, L. Huelsbergen, and G. G. Plunk, “Investigations on Informationally Complete Measurements,” in preparation.
- [64] R. Jozsa, “Entanglement and Quantum Computation,” in *The Geometric Universe: Science, Geometry, and the Work of Roger Penrose*, edited by S. A. Huggett, L. J. Mason, K. P. Tod, S. T. Tsou, and N. M. J. Woodhouse, (Oxford U. Press, Oxford, 1998), p. 369.
- [65] N. D. Mermin, *Boojums All the Way Through: Communicating Science in a Prosaic Age*, (Cambridge U. Press, Cambridge, 1990).
- [66] R. Bhatia, *Matrix Analysis*, (Springer-Verlag, New York, 1997).
- [67] N. R. Wallach, “An Unentangled Gleason’s Theorem,” [quant-ph/0002058](https://arxiv.org/abs/quant-ph/0002058).



- [68] D. Aerts and I. Daubechies, “Physical Justification for Using the Tensor Product to Describe Two Quantum Systems as One Joint System,” *Helv. Phys. Acta* **51**, 661–675 (1978); D. Aerts, “Subsystems in Physics Described by Bi-linear Maps between the Corresponding Vector Spaces,” *J. Math. Phys.* **21**, 778–788 (1980); M. Kläy, C. Randall, and D. Foulis, “Tensor Products and Probability Weights,” *Int. J. Theor. Phys.* **26**, 199–219 (1987); M. Kläy, “EPR Experiments: The Structure of the Sample Space,” *Found. Phys. Lett.* **1**, 205–243 (1988); A. Wilce, “Tensor Products in Generalized Measure Theory,” *Int. J. Theor. Phys.* **31**, 1915–1928 (1992).
- [69] C. H. Bennett, D. P. DiVincenzo, C. A. Fuchs, T. Mor, E. Rains, P. W. Shor, J. A. Smolin, and W. K. Wootters, “Quantum Nonlocality without Entanglement,” *Phys. Rev. A* **59**, 1070–1091 (1999).
- [70] S. MacLane and G. Birkhoff, *Algebra*, (Macmillan, New York, 1967).
- [71] H. Araki, “On a Characterization of the State Space of Quantum Mechanics,” *Comm. Math. Phys.* **75**, 1–24 (1980); W. K. Wootters, “Local Accessibility of Quantum Information,” in *Complexity, Entropy and the Physics of Information*, edited by W. H. Zurek (Addison-Wesley, Redwood City, CA, 1990), p. 29–46.
- [72] A. Wilce, “Tensor Product of Frame Manuals,” *Int. J. Theor. Phys.* **29**, 805–814 (1990)
- [73] R. S. Cohen, M. Horne, and J. Stachel, editors, *Potentiality, Entanglement and Passion-at-a-Distance*, (Kluwer, Dordrecht, 1997).
- [74] C. M. Caves, C. A. Fuchs, and R. Schack, “Bayesian Probability in Quantum Mechanics,” in preparation (2002).
- [75] H. E. Kyburg, Jr. and H. E. Smokler, eds., *Studies in Subjective Probability*, Second Edition (Robert E. Krieger Publishing, Huntington, NY, 1980).
- [76] E. T. Jaynes, *Probability Theory: The Logic of Science*, available for download on the World Wide Web at <http://bayes.wustl.edu/>. This huge book was unfortunately never finished due to Prof. Jaynes’ death in 1998. Nevertheless, it stands as perhaps the most complete and persuasive document in the field.
- [77] J. M. Bernardo and A. F. M. Smith, *Bayesian Theory* (Wiley, Chichester, 1994).
- [78] N. D. Mermin, “From Classical State-Swapping to Quantum Teleportation,” *Phys. Rev. A* **65**, 012320-1–012320-6 (2002).
- [79] B. Schumacher, “Sending Quantum Entanglement Through Noisy Channels,” *Phys. Rev. A* **54**, 2614–2628 (1996).
- [80] T. M. Cover and J. A. Thomas, *Elements of Information Theory*, (John Wiley & Sons, New York, 1991).
- [81] R. B. Ash, *Information Theory*, (Dover, New York, 1965).
- [82] A. Wehrl, “General Properties of Entropy,” *Rev. Mod. Phys.* **50**, 221–259 (1978).
- [83] W. K. Wootters, “Random Quantum States,” *Found. Phys.* **20**, 1365–1378 (1990); K. R. W. Jones, “Riemann-Liouville Fractional Integration and Reduced Distributions on Hyperspheres,” *J. Phys. A* **24**, 1237–1244 (1991).
- [84] R. Jozsa, D. Robb, and W. K. Wootters, “Lower Bound for Accessible Information in Quantum Mechanics,” *Phys. Rev. A* **49**, 668–677 (1994).
- [85] C. A. Fuchs and K. Jacobs, “Information Tradeoff Relations for Finite-Strength Quantum Measurements,” in *Phys. Rev. A* **63**, 062305-1–062305-15 (2001).
- [86] M. A. Nielsen, “Characterizing Mixing and Measurement in Quantum Mechanics,” *Phys. Rev. A* **63**, 022114-1–022114-11 (2001).
- [87] R. Schatten, *Norm Ideals of Completely Continuous Operators*, (Springer-Verlag, Berlin, 1960).
- [88] H. M. Wiseman, “Using Feedback to Eliminate Back-Action in Quantum Measurements,” *Phys. Rev. A* **51**, 2459–2468 (1995).; J. Audretsch, L. Diósi, and T. Konrad, “Evolution of a Qubit under the Influence of a Succession of Unsharp Measurements,” [quant-ph/0201078](http://arxiv.org/abs/quant-ph/0201078).

- [89] J. Bub, “Von Neumann’s Projection Postulate as a Probability Conditionalization Rule in Quantum Mechanics,” *J. Phil. Logic* **6**, 381–390 (1977)
- [90] S. L. Braunstein and C. M. Caves, “Wringing Out Better Bell Inequalities,” *Ann. Phys.* **202**, 22–56 (1990).
- [91] M. Ozawa, “Quantum State Reduction and the Quantum Bayes Principle,” in *Quantum Communication, Computing, and Measurement*, edited by O. Hirota, A. S. Holevo, and C. M. Caves (Plenum Press, New York, 1997), pp. 233–241; M. Ozawa, “An Operational Approach to Quantum State Reduction,” *Ann. Phys.* **259**, 121–137 (1997); M. Ozawa, “Quantum State Reduction: An Operational Approach,” *Fortschr. Phys.* **46**, 615–625 (1998).
- [92] R. Duvenhage, “The Nature of Information in Quantum Mechanics,” [quant-ph/0203070](#).
- [93] B. C. van Fraassen, private communication, 11 April 2002.
- [94] G. Boole, *An Investigation of the Laws of Thought*, (Dover, New York, 1958).
- [95] T. A. Brun, J. Finkelstein, and N. D. Mermin, “How Much State Assignments Can Differ,” *Phys. Rev. A* **65**, 032315-1–032315-3 (2002).
- [96] C. M. Caves, C. A. Fuchs, and R. Schack, “Compatible Quantum States: Coming to Agreement and Uncovering Disagreement,” in preparation.
- [97] C. M. Caves, private communication, as early as 10 September 1999.
- [98] G. Vidal and J. I. Cirac, “Storage of Quantum Dynamics in Quantum States: A Quasi-Perfect Programmable Quantum Gate,” [quant-ph/0012067](#); W. Dür and J. I. Cirac, “Non-local Operations: Purification, Storage, Compression, Tomography, and Probabilistic Implementation,” *Phys. Rev. A* **64**, 012317-1–012317-14 (2001); S. F. Huelga, J. A. Vaccaro, A. Chefles, and M. B. Plenio, “Quantum Remote Control: Teleportation of Unitary Operations,” *Phys. Rev. A* **63**, 042303-1–042303-4; G. Vidal, L. Masanes, and J. I. Cirac, “Storing Quantum Dynamics in Quantum States: A Stochastic Programmable Gate,” *Phys. Rev. Lett.* **88**, 047905-1–047905-4 (2002); C.-P. Yang and J. Gea-Banacloche, “Teleportation of Rotations and Receiver-Encoded Secret Sharing,” *J. Opt. B* **3**, 407–411 (2001); S. F. Huelga, M. B. Plenio, and J. A. Vaccaro, “Remote Control of Restricted Sets of Operations: Teleportation of Angles,” *Phys. Rev. A* **65**, 042316-1–042316-12 (2002).
- [99] A. Jamiołkowski, “Linear Transformations which Preserve Trace and Positive Semidefiniteness of Operators,” *Rep. Math. Phys.* **3**, 275–278 (1972).
- [100] M.-D. Choi, “Completely Positive Linear Maps on Complex Matrices,” *Lin. Alg. App.* **10**, 285–290 (1975).
- [101] P. W. Shor, “Scheme for Reducing Decoherence in Quantum Computer Memory,” *Phys. Rev. A* **52**, R2493 (1995); A. M. Steane, “Error Correcting Codes in Quantum Theory,” *Phys. Rev. Lett.* **77**, 793 (1996).
- [102] C. H. Bennett and G. Brassard, “Quantum Cryptography: Public Key Distribution and Coin Tossing,” in *Proc. IEEE International Conference on Computers, Systems and Signal Processing* (IEEE Press, New York, 1984), p. 175, IEEE, 1984; C. H. Bennett, “Quantum Cryptography Using Any Two Nonorthogonal States,” *Phys. Rev. Lett.* **68**, 3121 (1992).
- [103] S. J. van Enk and C. A. Fuchs, “Quantum State of an Ideal Propagating Laser Field,” *Phys. Rev. Lett.* **88**, 027902-1–027902-4 (2002); S. J. van Enk and C. A. Fuchs, “Quantum State of a Propagating Laser Field,” *Quant. Info. Comp.* **2**, 151–165 (2002).
- [104] B. de Finetti, *Theory of Probability* (Wiley, New York, 1990); For a collection of Finetti’s original papers and their translations into English, see P. Monari and D. Cocchi, editors, *Probabilità e Induzione—Induction and Probability* (Biblioteca di Statistica, CLUEB, Bologna, 1993).
- [105] R. L. Hudson and G. R. Moody, “Locally Normal Symmetric States and an Analogue of de Finetti’s Theorem,” *Z. Wahrschein. verw. Geb.* **33**, 343–351 (1976).
- [106] E. C. G. Stueckelberg, “Quantum Theory in Real Hilbert Space,” *Helv. Phys. Acta* **33**, 727 (1960); S. L. Adler, *Quaternionic Quantum Mechanics and Quantum Fields* (Oxford U. Press, New York, 1995).

- [107] C. H. Bennett, G. Brassard, and N. D. Mermin, “Quantum Cryptography without Bell’s Theorem,” *Phys. Rev. Lett.* **68**, 557–559 (1992); C. A. Fuchs, “Information Gain vs. State Disturbance in Quantum Theory,” *Fort. der Phys.* **46**, 535–565 (1998).
- [108] C. A. Fuchs and A. Peres, “Quantum State Disturbance vs. Information Gain: Uncertainty Relations for Quantum Information,” *Phys. Rev. A* **53**, 2038–2045 (1996); C. A. Fuchs, N. Gisin, R. B. Griffiths, C.-S. Niu, and A. Peres, “Optimal Eavesdropping in Quantum Cryptography. I. Information Bound and Optimal Strategy,” *Phys. Rev. A* **56**, 1163–1172 (1997); D. Bruss, “Optimal Eavesdropping in Quantum Cryptography with Six States,” *Phys. Rev. Lett.* **81**, 2598–2601 (1998); K. Banaszek and I. Devetak, “Fidelity Trade-off for Finite Ensembles of Identically Prepared Qubits,” *Phys. Rev. A* **64**, 052307-1–052307-14 (2001).
- [109] R. W. Spekkens and T. Rudolph, “Degrees of Concealment and Bindingness in Quantum Bit Commitment Protocols,” *Phys. Rev. A* **65**, 012310-1–012310-10 (2001); R. W. Spekkens and T. Rudolph, “Optimization of Coherent Attacks in Generalizations of the BB84 Quantum Bit Commitment Protocol,” *Quant. Inf. Comp.* **2**, 66–96 (2002); R. W. Spekkens and T. Rudolph, “A Quantum Protocol for Cheat-Sensitive Weak Coin Flipping,” [quant-ph/0202118](#); L. Hardy and A. Kent, “Cheat Sensitive Quantum Bit Commitment,” [quant-ph/9911043](#).
- [110] R. Blume-Kohout, C. M. Caves, and I. H. Deutsch, “Climbing Mount Scalable: Physical-Resource Requirements for a Scalable Quantum Computer,” [quant-ph/0204157](#).
- [111] E. T. Jaynes, “The de Finetti System of Probability,” in Appendix A, “Other Approaches to Probability Theory,” of Ref. [76].
- [112] M. Fortun and H. J. Bernstein, *Muddling Through: Pursuing Science and Truths in the Twenty-First Century*, (Counterpoint, Washington, DC, 1998).